

**PARTS LIST:**

1	LD2 Skid Plate	4	8-1.25mm x 25mm Button Head Bolts
2	12-1.75mm x 120mm Hex Bolts	4	8mm Lock Washers
4	12mm x 32mm x 3mm Flat Washers	4	8mm x 24mm x 2mm Flat Washers
2	12mm Nylon Lock Nuts	1	5mm Hex Wrench

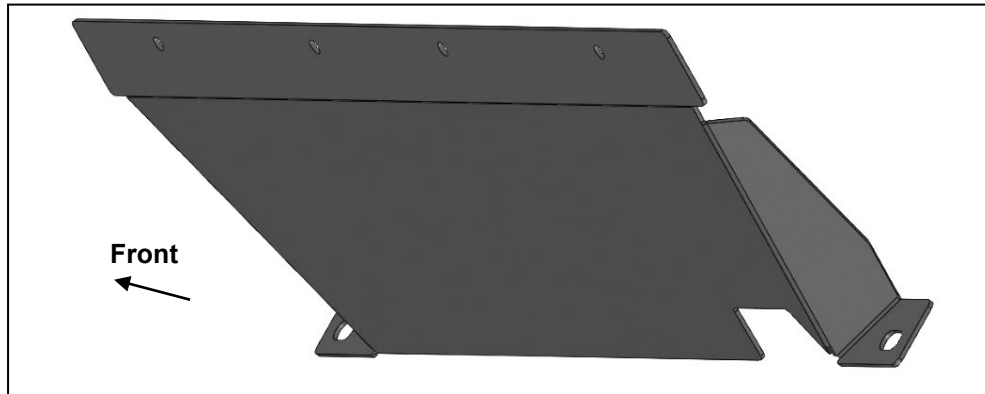

**PROCEDURE:**

**REMOVE CONTENTS FROM BOX. VERIFY ALL PARTS ARE PRESENT. READ INSTRUCTIONS CAREFULLY BEFORE STARTING INSTALLATION. ASSISTANCE IS RECOMMENDED.**

- Carefully unwrap the Skid Plate. With assistance, line up the front of the Skid Plate with the back of the Bumper. Attach the Skid Plate to the Bumper with the included (4) 8mm Button Head Bolts, (4) 8mm Lock Washers and (4) 8mm Flat Washers, **(Figure 1)**. Leave hardware loose at this time.
- Attach the mounting tabs on the Skid Plate to the large holes in the front of the frame with (2) 12mm x 120mm Hex Bolts, (4) 12mm Flat Washers and (2) 12mm Nylon Lock Nuts, **(Figures 2—4)**.
- Level and adjust the Skid Plate and fully tighten all hardware. **NOTE:** Do not overtighten lower hex bolts or damage to the frame may result.
- Do periodic inspections to the installation to make sure that all hardware is secure and tight.

**To protect your investment,** Do not use any type of polish or wax that may contain abrasives that could damage the finish. Mild soap may be used to clean the Skid Plate.

(4) 8mm x 25mm Button Head Bolts  
(4) 8mm Lock Washers  
(4) 8mm Flat Washers

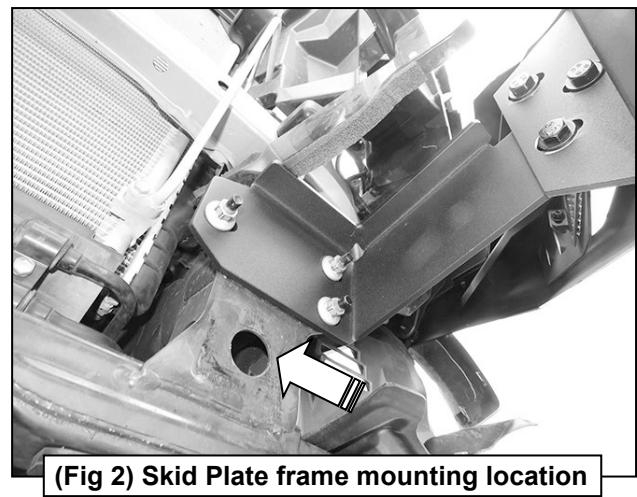
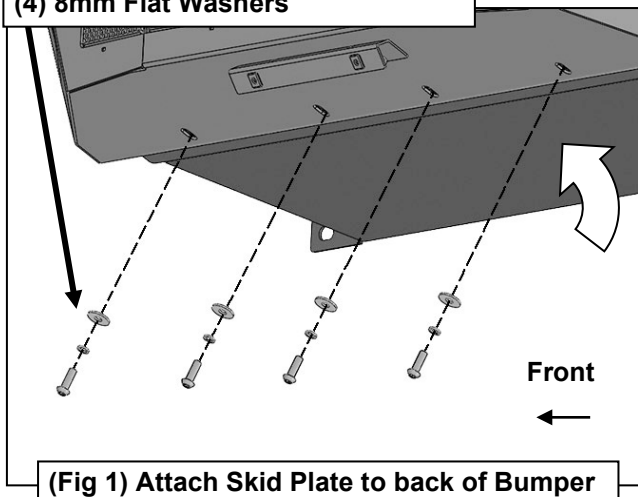

Driver/left Installation Pictured

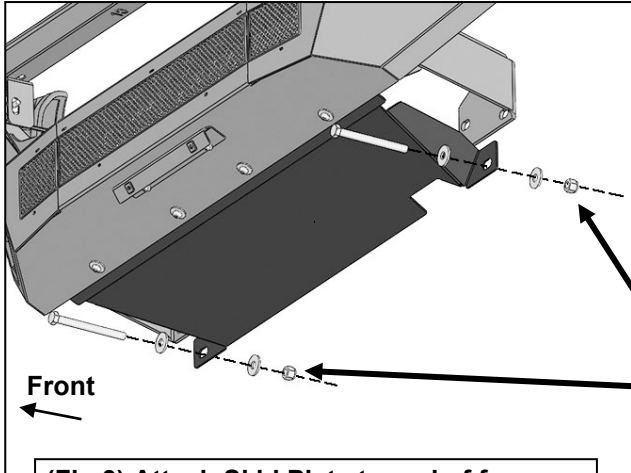

(Fig 3) Attach Skid Plate to end of frame

- (2) 12mm x 120mm Hex Bolts
- (4) 12mm Flat Washers
- (2) 12mm Nylon Lock Nuts

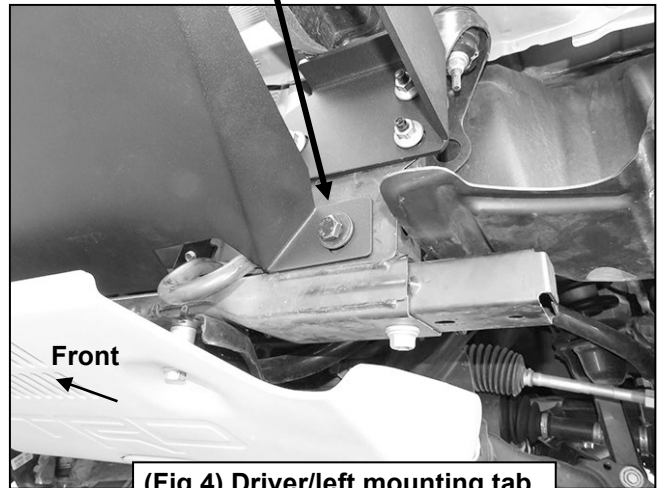

(Fig 4) Driver/left mounting tab on Skid Plate attached to frame

