

PROVEN GROUND

Premium EZ Hard Fold Tonneau

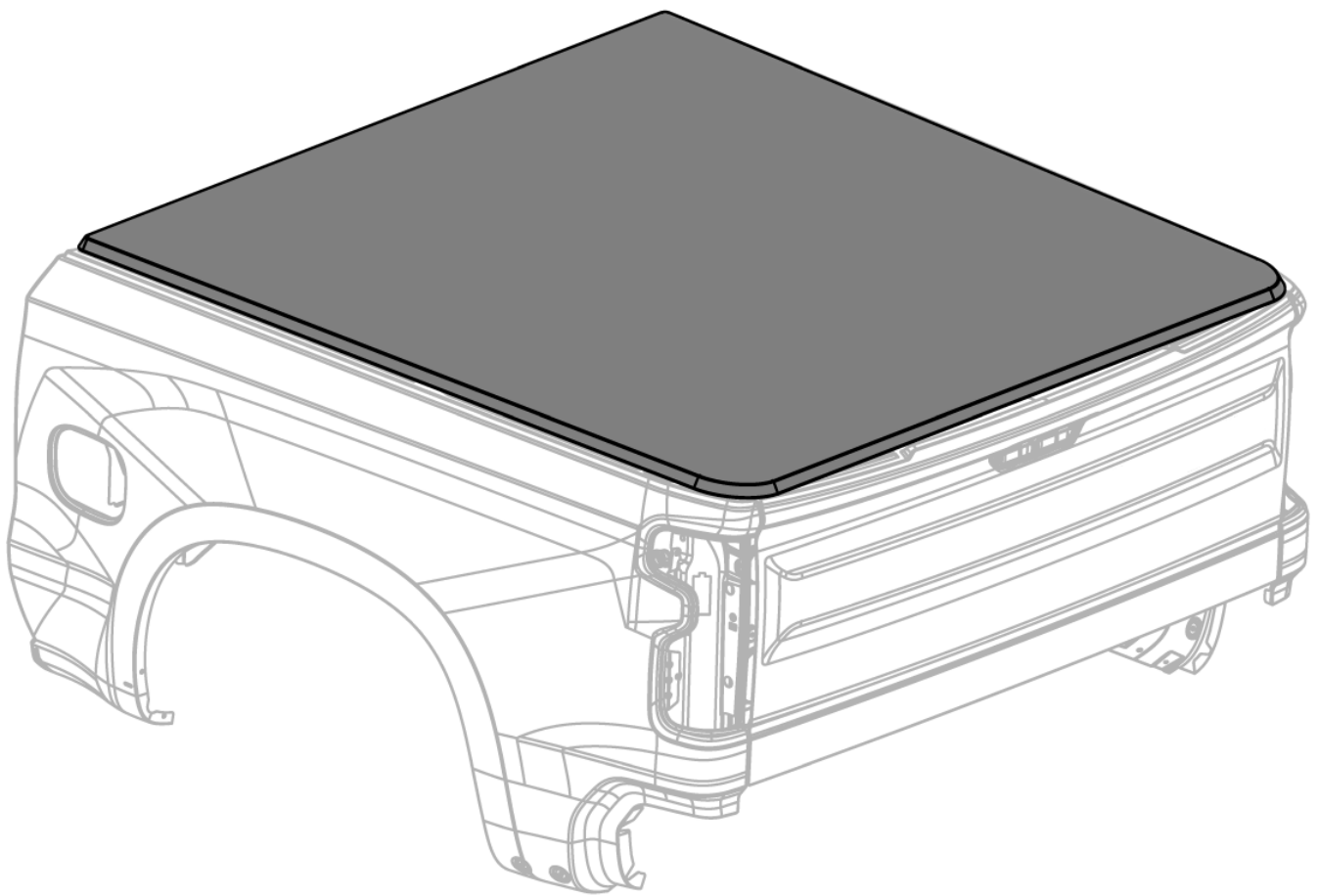

INSTALLATION

Parts included in the Assembly:

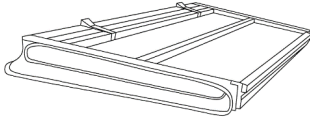
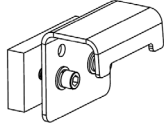
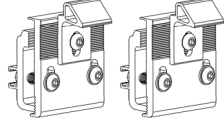
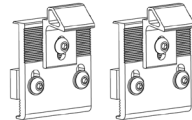
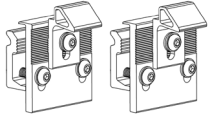
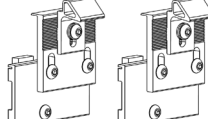
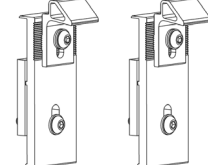
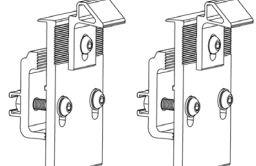
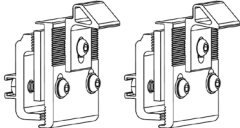
Item	Description	Qty	Picture
A	Assembled Tri-fold Cover	1	
H	* Track Bracket--For truck with Utility Track system only , please read page 5/15, to set up bracket on Track system.	2	
R	Rear Locking Adapter Adapter-A, for truck bed without Utility Track System	2	 → A
	Adapter-B, for truck bed with Utility Track System only. (22#23#24#30#34#37#39#45#64#65#47#48#109)		 → B
	Adapter-C, NISSAN Frontier (40#41#)		 → C
	Adapter-D , 2015+ Colorado/Canyon 2014-2016 Silverado/Sierra 2019+ Silverado/Sierra (05#29#60#61#103#104#)		 → D
	Adapter-E, 2007-2013 Silverado/Sierra (28#31#)		 → E
	Adapter-F, 2004-2006 Tundra Double Cab 1999-2006 Tundra Access Cab (25#26#)		 → F
	Adapter-G, 2019+ Ford Ranger (106#107#)		 → G

Check contents of carton with the list above. Clean truck thoroughly before installation.

Step 1

Place assembled cover over cab front end of truck box.

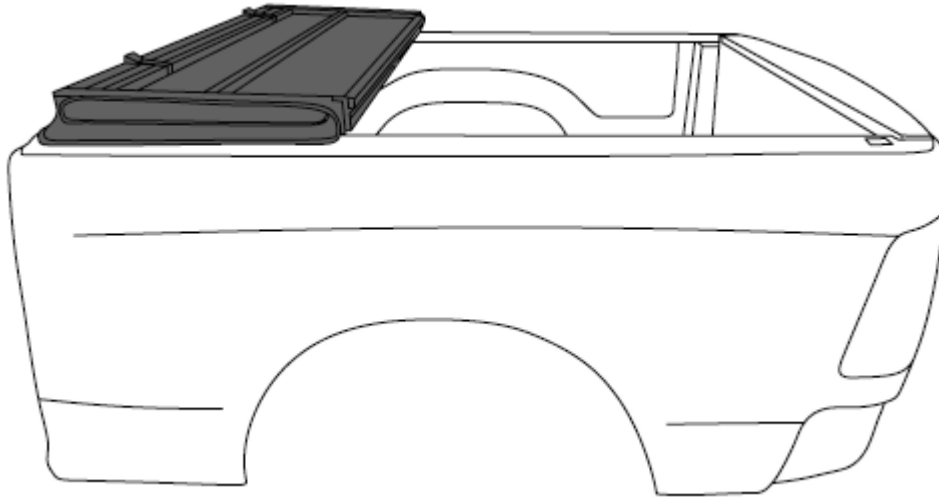

Step 2

Unfold the cover fully and adjust position over the truck bed for proper alignment on cab/tail.

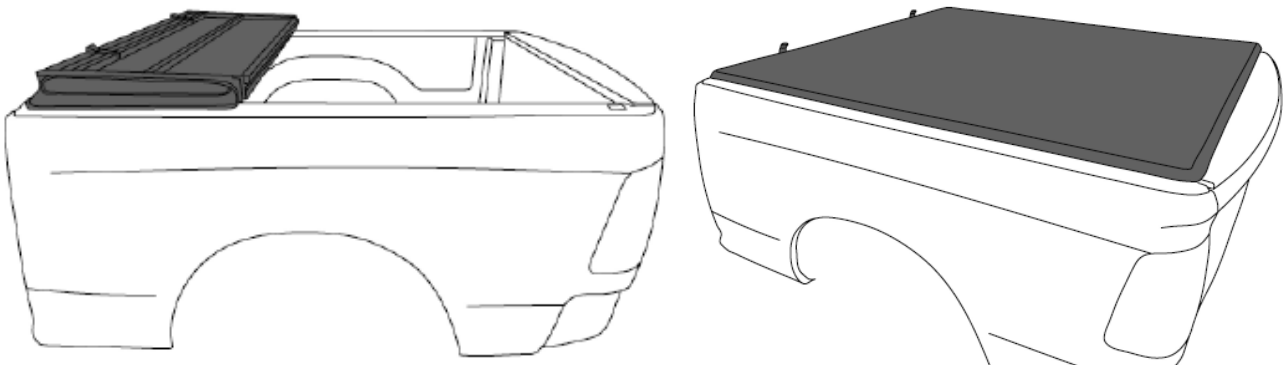

Step 3

Carefully refold the cover without shifting its position on the truck bed.

Step 4

Take off the clamp bolt from cover rail. Adjust the clamping bolt to proper position. Move the bolt base to secure position.

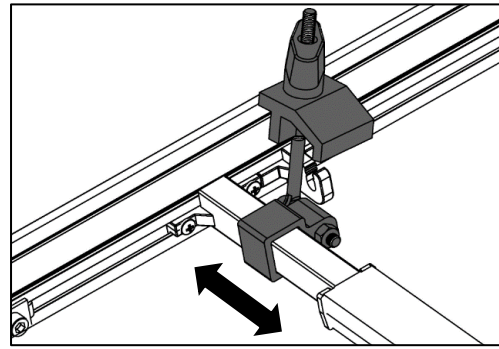
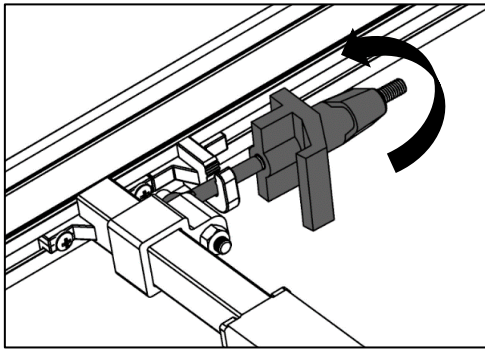

Step 5 (For truck without Utility Track system)

Secure the Front Clamps (left and right) by tightening the clamp handle up to clamp the metal bed wall edge of truck. Note: If necessary, adjust the clamp position by rotating the clamp on the bolt to ensure the clamp is tightly clamped on the metal bed wall edge of truck. Do not secure to only lip of bedliner or rail cap.

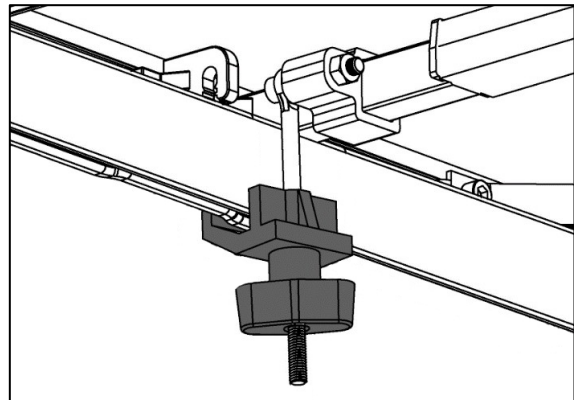
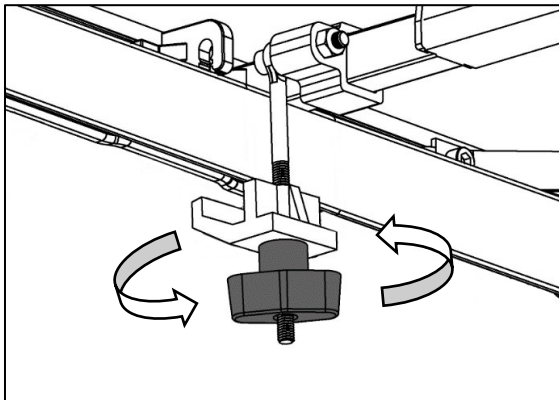

Step 5 (For truck with Utility Track system)

*Slide the retainer plates (on the Track Brackets—Part #H) into the side channels on the vehicle bed. (2 goes in front, 1 per side)

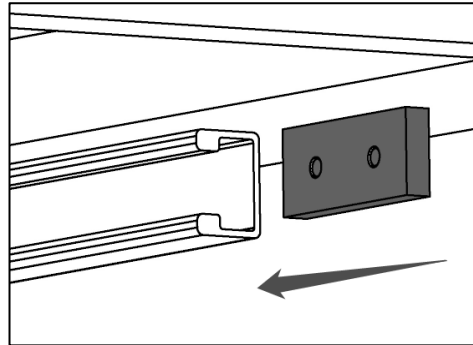

*Attach the clamp bracket to the plate with the included Allen head bolts.

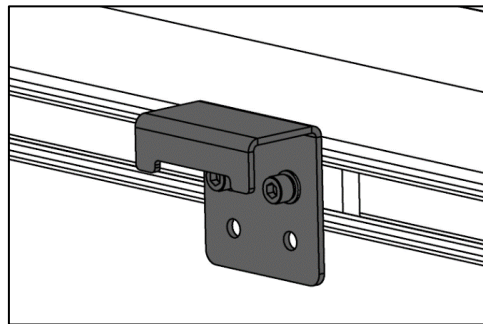

* Secure Tri-fold Cover latches (Front Clamp Knobs) to these brackets.

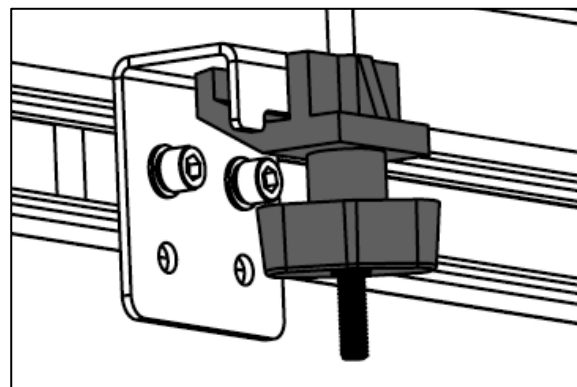
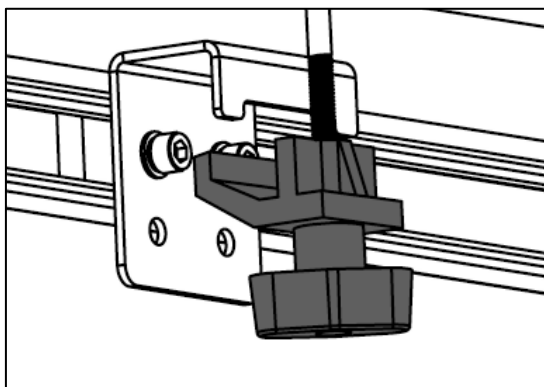

Step 6

Safety Strap Instructions (Not for truck bed with Utility Track System)

When you open the cover there are two safety buckles near the front clamps.

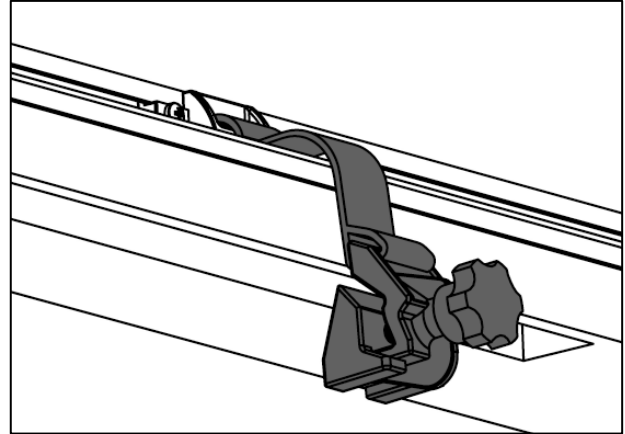
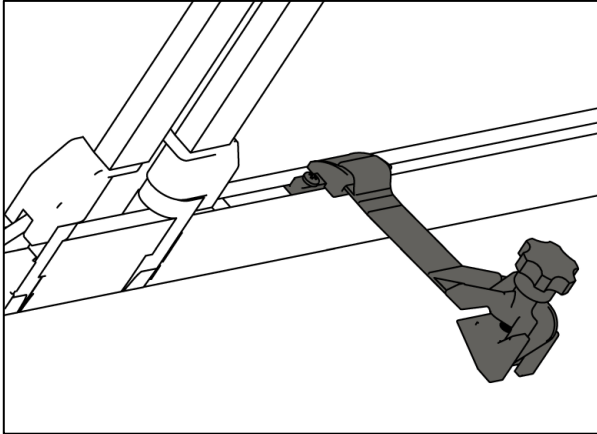

When the front clamps are secured, install the safety strap (see the photos). Tighten the knob of the safety straps.

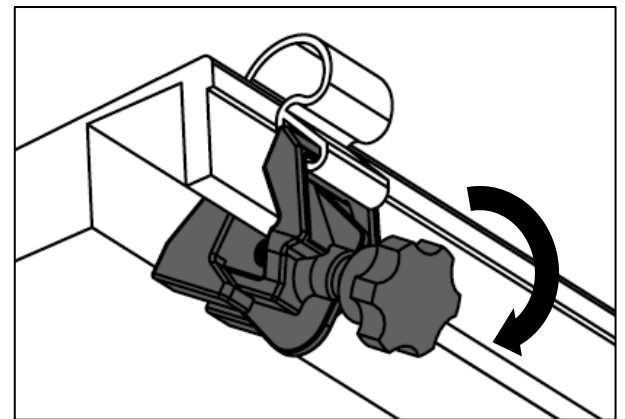
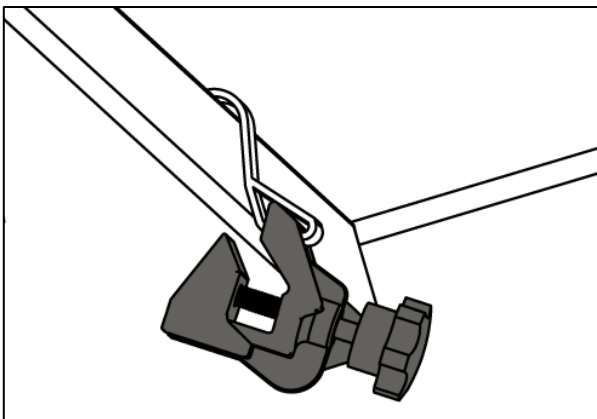

WARNING:

Always secure the safety straps to the truck bed. Never drive with a cover in partially opened position.

Step 7

Rear Locking Adapter Installation:

Unfold the cover fully. Place the Rear Locking Adapter under the Cover latch system, and install the adapter clamps on the truck bed inner wall with bolts (see below options). Tighten the Adapter each side.

If you receive Adapter A or F, please go to page **8/15*

---- **(For truck bed without Utility Track System)**

If you receive Adapter B, please go to page **9/15*

---- **(For truck bed with Utility Track System only)**

If you receive Adapter C, please go to page **10/15*

---- **(NISSAN Frontier)**

If you receive Adapter D, please go to page **11/15*

---- **(2015+ Colorado/Canyon, 2014-2016 Silverado/Sierra,
2019+ Silverado/Sierra)**

If you receive Adapter E, please go to page **12/15*

---- **(2007-2013 Silverado/Sierra)**

If you receive Adapter G, please go to page **13/15*

---- **(2019+ Ford Ranger)**

Step 8

Unfold the cover and close the door.

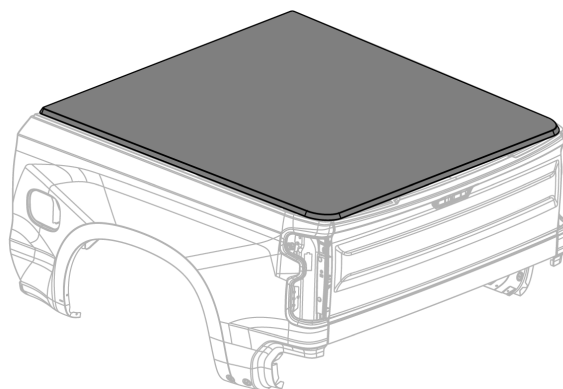

For truck bed without Utility Track System

1. Put the clamp inner block into the bed inner wall, and then fix the clamp outer block to the inner clamp block with bolts. (Do not tighten the bolt)

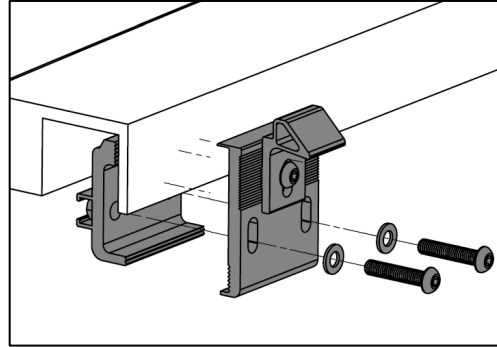
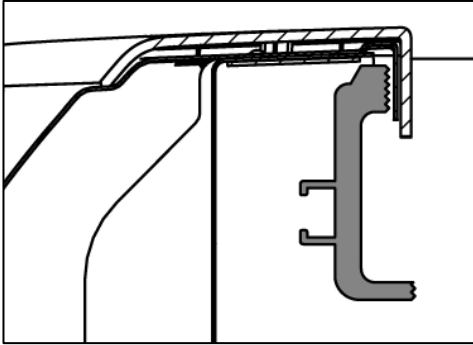

2. Close the cover, move the block, make sure the adapter tongue is under the cover latch system. Adjust the adapter, to make sure the tongue is in the Middle of cover aluminum groove.

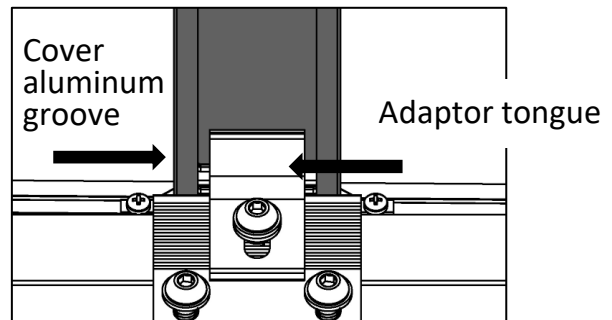
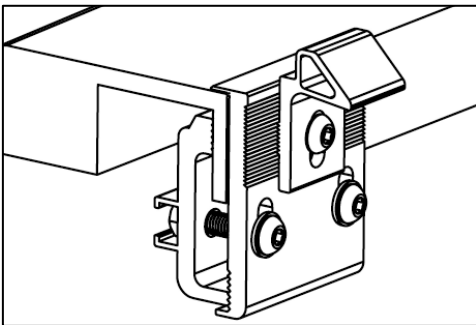

3. Make sure the lip of outer block is sit firmly on the bed rail, and tighten all screws/bolts.

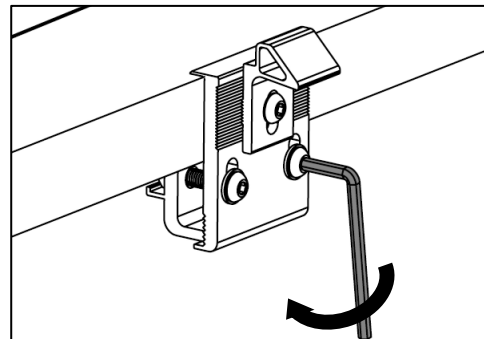
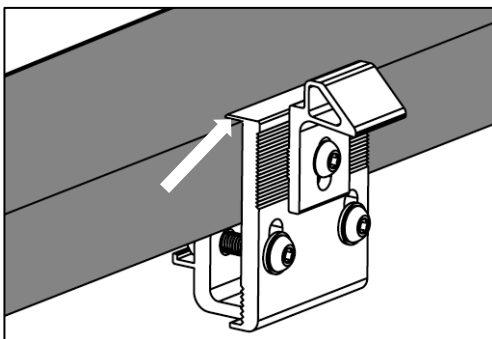

For truck bed with Utility Track System only

1. Put the slide block into the track, and then fix the external clamp block to the slide block with bolts. (Do not tighten the bolts)

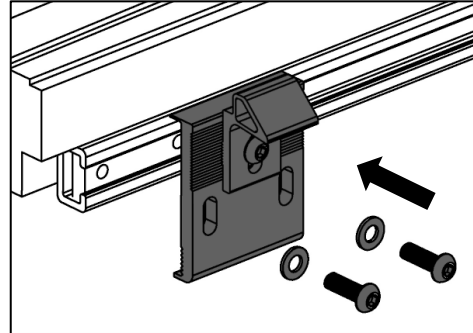
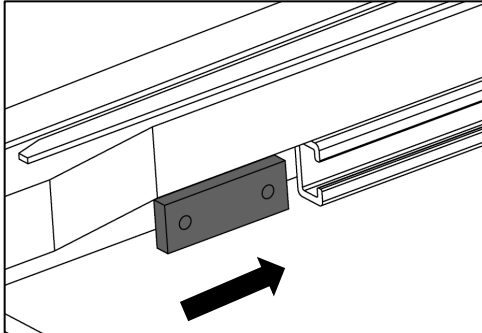

2. Close the cover, move the block, make sure the adapter tongue is under the cover latch system. Adjust the adapter, to make sure the tongue is in the Middle of cover aluminum groove

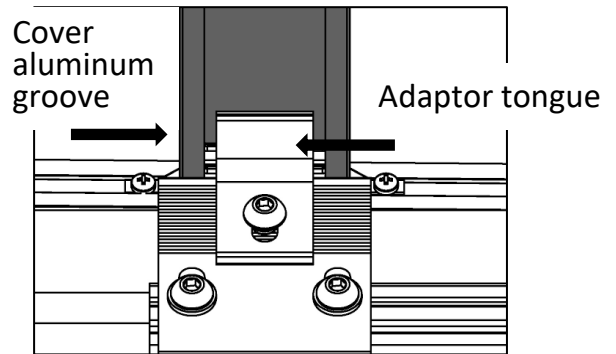
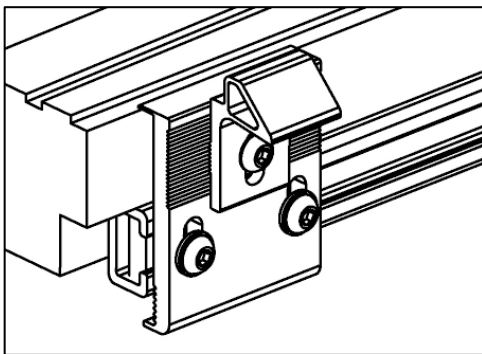

3. Make sure the lip of outer block is sit firmly on the bed rail, and tighten all screws/bolts.

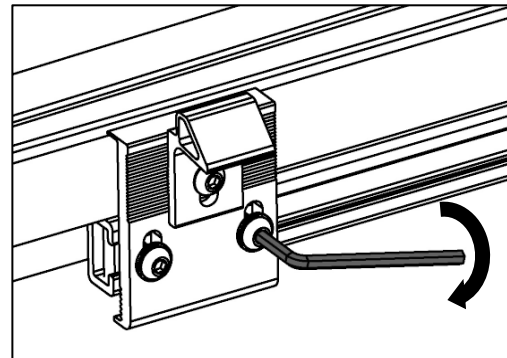
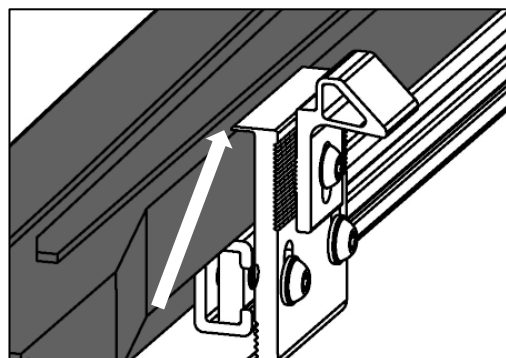

NISSAN Frontier

1. Put the inner clamp block into the gap Above the track, and then fix the outer clamp block to the inner clamp block with bolts. (Do not tighten the bolt)

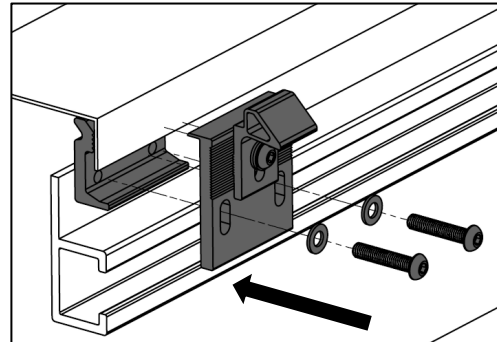
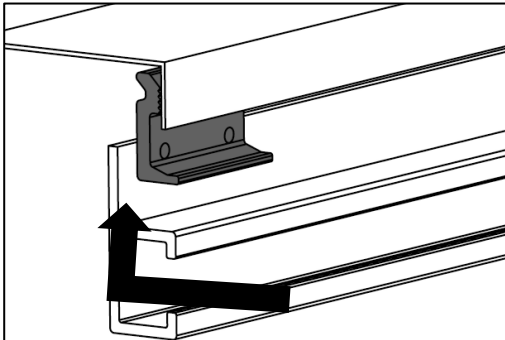

2. Close the cover, move the block, make sure the adapter tongue is under the cover latch system. Adjust the adapter, to make sure the tongue is in the Middle of cover aluminum groove

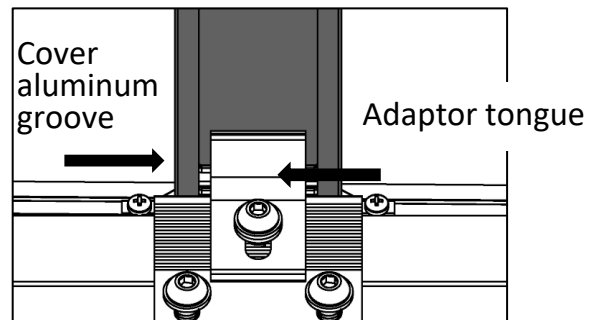
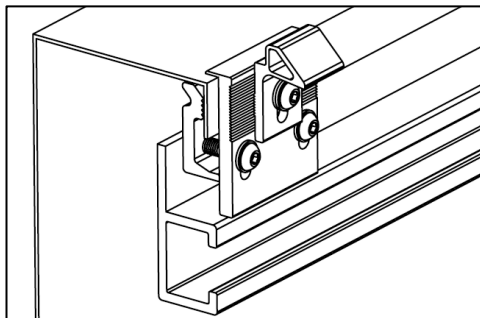

3. Make sure the lip of outer block is sit firmly on the bed rail, and tighten all screws/bolts.

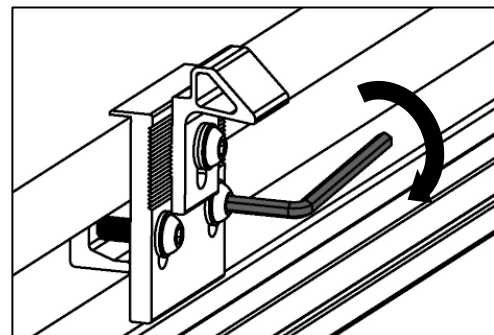
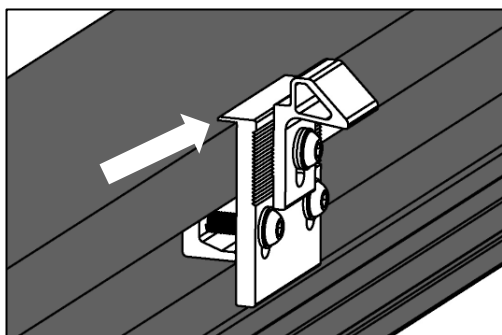

2015 + Colorado/Canyon & 2014-2016 Silverado/Sierra & 2019 + Silverado/Sierra

1. Put the small aluminum square piece into the stake pocket hole, and then screw the large aluminum square piece fixed to the small aluminum square pc. (Do not tighten the screw)

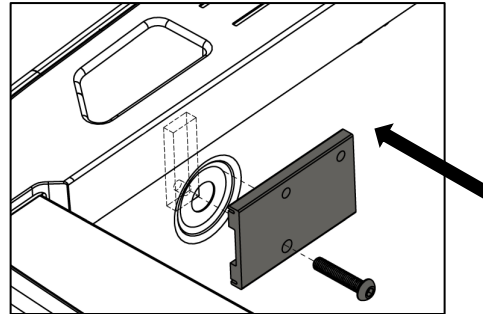
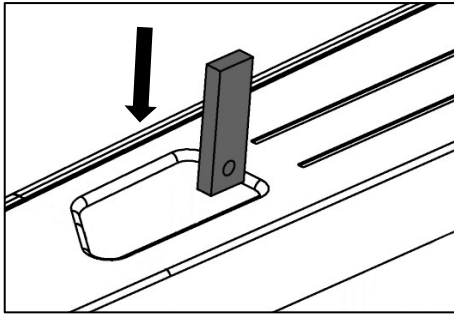

2. Screw the outer block to the large aluminum square pc, screw well and do not tighten.

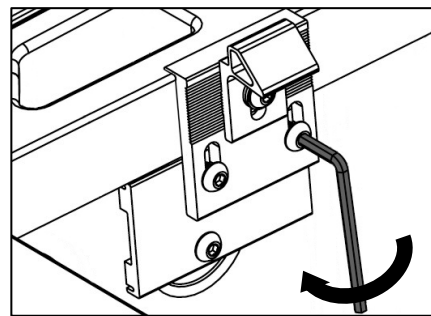
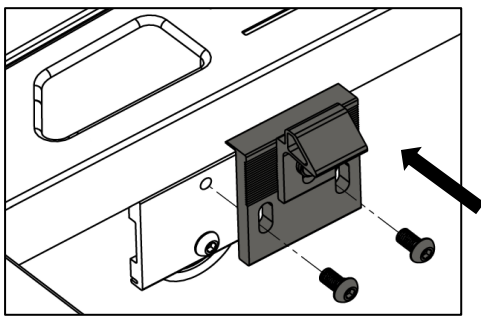

3. Close the cover, move the adapter tongue to match the cover latch system. Adjust the cover position, to make sure the Adapter tongue is in the Middle of cover aluminum groove. Make sure the lip of outer block is sit firmly on the bed rail, and tighten all screws/bolts.

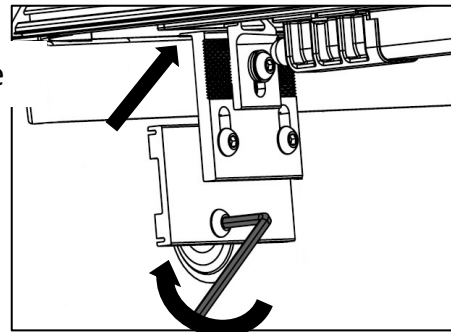
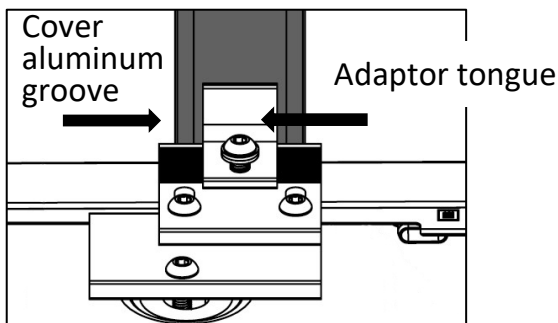

2007-2013 Silverado/Sierra

1. Put the small aluminum square piece into the stake pocket hole, and then screw the large aluminum square piece fixed to the small aluminum square pc. (Do not tighten the screw)

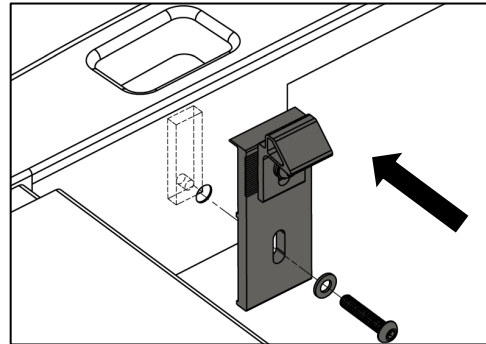
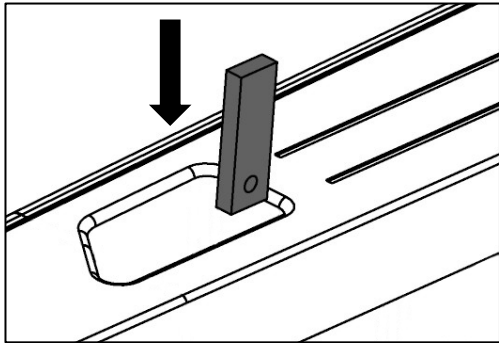

2. Close the cover, move the adapter tongue to match the cover latch system. Adjust the cover position, to make sure the adapter tongue is in the Middle of cover aluminum groove.

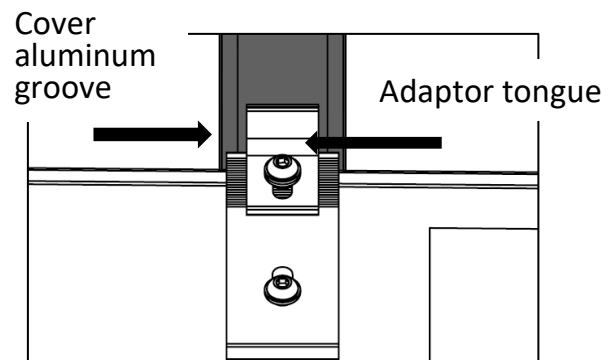
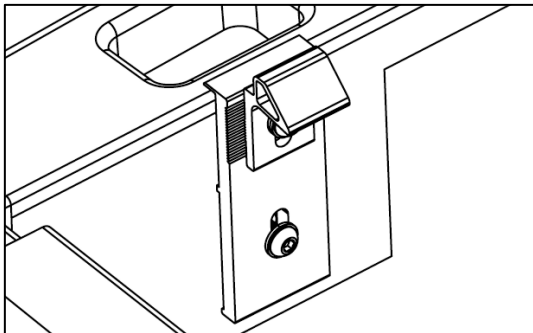

3. Make sure the lip of outer block is sit firmly on the bed rail, and tighten all screws/bolts.

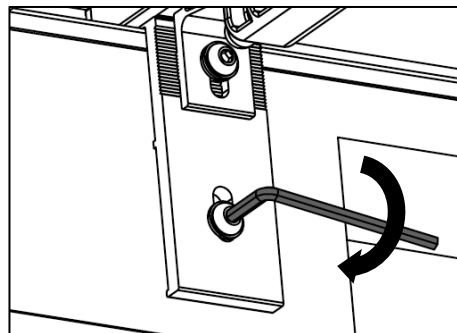
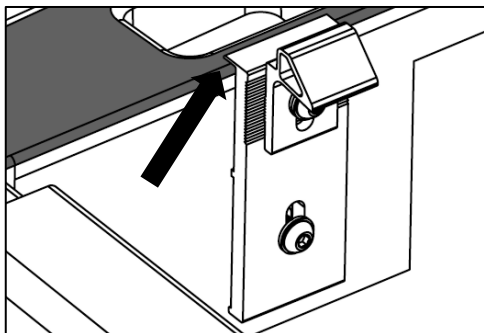

2019+ Ford Ranger

1. Loosen the long screw on the clamp so that the aluminum block in the middle of the clamp can be inserted between the plastic cover and the sheet metal of the truck bed inner wall. (Do not tighten the screw)

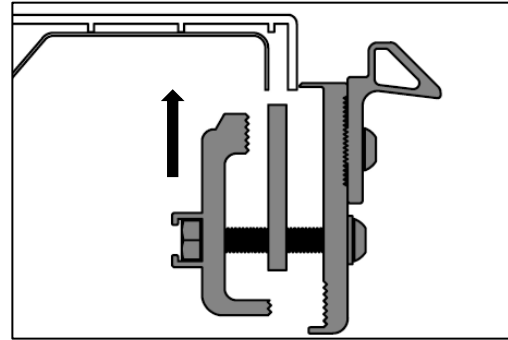
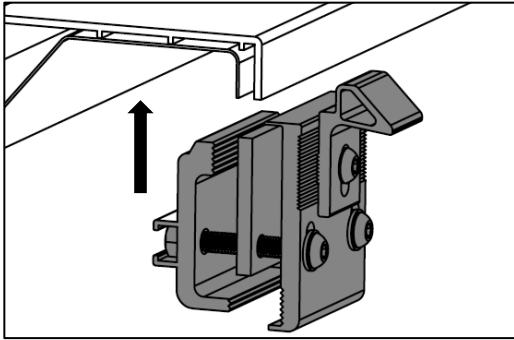

2. Close the cover, move the block, make sure the adapter tongue is under the cover latch system. Adjust the Adapter position to make sure the adapter tongue is in the Middle of cover aluminum groove.

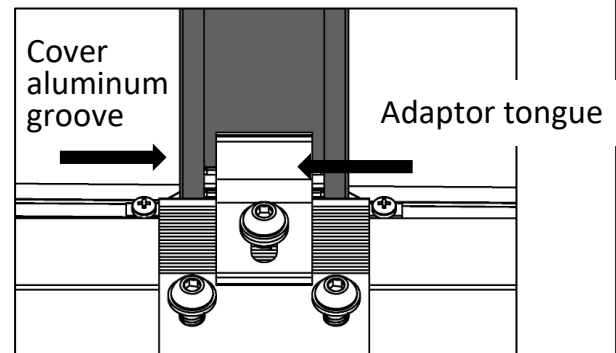
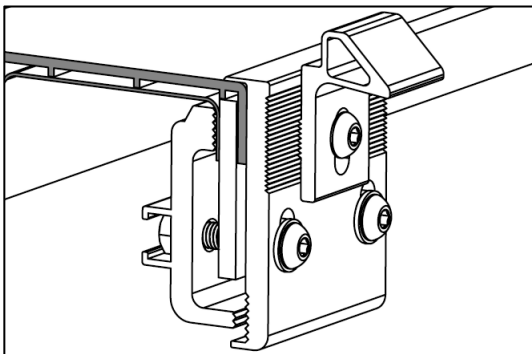

3. Make sure the lip of outer block is sit firmly on the bed rail, and tighten all screws/bolts.

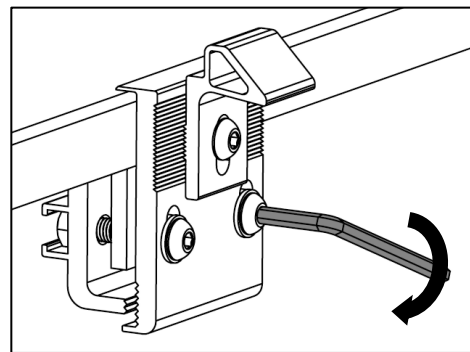
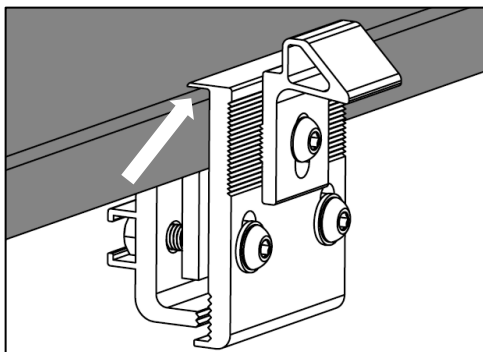

Troubleshooting

When installing the clamps, there are two possibilities.

- 1) There is a big gap between the locking tongue and Adapter-tongue. Just move the Adapter-tongue several teeth down.

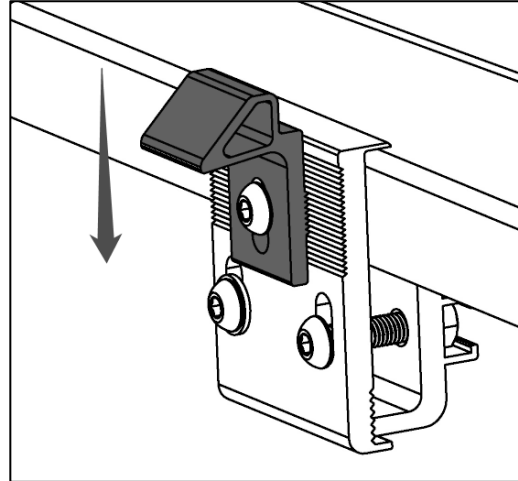
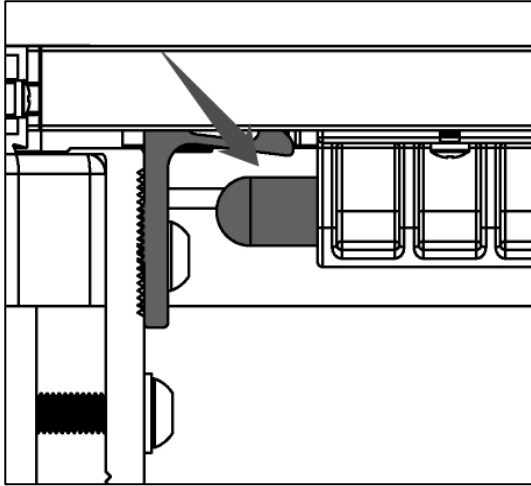

- 2) The cover can not be locked. Just move the Adapter-tongue several teeth up.

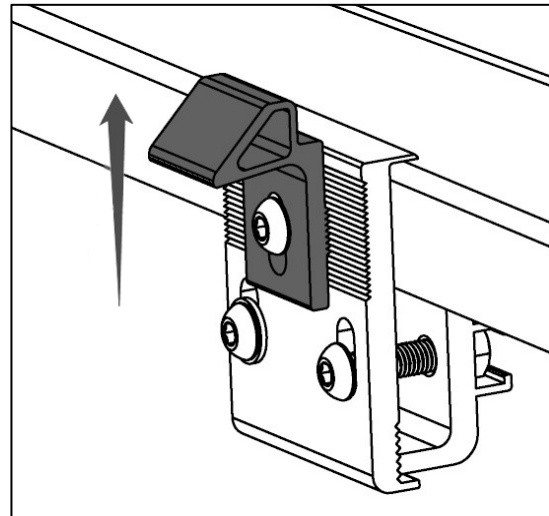
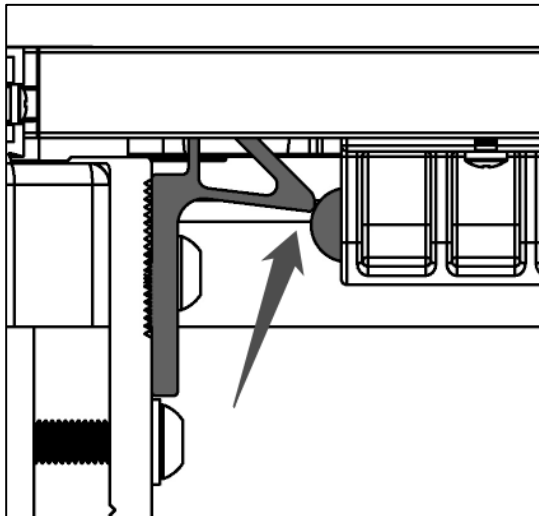

CLEANING

Clean with cold water and a cloth. Do not use a neutral soap and detergents. Do not expose to petrol, diesel, oils or chemicals of any nature.

WARNINGS

READ AND UNDERSTAND ALL INSTRUCTIONS. FAILURE TO FOLLOW ALL INSTRUCTIONS LISTED, FAIL TO READ MAY RESULT SERIOUS INJURY.

- **DO NOT CUT OR MODIFY THE TONNEAU COVER OR MOUNTING ACCESSORIES.**
- **DO NOT EXCEED THE VEHICLE MANUFACTURER'S WEIGHT LIMITS.**
- **DO NOT USE DAMAGED OR EXCESSIVELY WORN PRODUCTS. CONTACT US IF YOU ARE UNSURE.**
- **THE WARNINGS, CAUTIONS, AND INSTRUCTIONS DISCUSSED IN THIS INSTRUCTION MANUAL CANNOT COVER ALL POSSIBLE CONDITIONS OR SITUATIONS THAT COULD OCCUR. IT MUST BE UNDERSTOOD BY THE OPERATOR THAT COMMON SENSE AND CAUTION ARE FACTORS WHICH CANNOT BE BUILT INTO THIS PRODUCT, BUT MUST BE SUPPLIED BY THE OPERATOR.**

INSTALLATION PRECAUTIONS

- Follow DOT regulations regarding installation and use.
- Park truck on a flat, level, hard surface well away from traffic. Place transmission in park.
- Verify that installation surface has no hidden wires before drilling or driving screws.
- Install only according to these instructions. Improper installation can create hazards.
- Wear ANSI-approved safety goggles and heavy-duty work gloves during assembly and installation.
- Keep installation area clean and well lit.
- Keep bystanders out of the area during installation.
- Do not install when tired or when under the influence of drugs or medication.
- Weight capacity and other product capabilities apply to properly and completely installed product only.

USE PRECAUTIONS

- Do not exceed rated weight capacity of Tonneau Cover.
- Use as intended only.
- Inspect before every use; do not use if parts loosen or damaged.
- This product is not a toy. Do not allow children to play with or near this item.
- Maintain product labels and nameplates. These carry important safety information.
- The warnings, precautions, and instructions discussed in this instruction manual cannot cover all possible conditions and situations that may occur. It must be understood by the operator that common sense and caution are factors which cannot be built into this product, but must be supplied by the operator.