

INSTALLATION INSTRUCTIONS
PR1 PLATFORM FULL EXTENSION
2018-21 JEEP WRANGLER JL 4 DOOR WITH HARD TOP
J163316

**PR1 PLATFORM FULL EXTENSION
2018-21 JEEP WRANGLER JL 4 DOOR WITH HARD TOP**

PARTS LIST:

2	Cross Bars	4	8mm x 25mm Combo Hex Bolts
2	Extension Tubes	4	8mm x 25mm Button Head Bolts
2	Plastic Joints	4	8mm Lock Washers
1	Wind Fairing Plate	4	8mm x 24mm OD x 2mm Flat Washers
4	Connecting Brackets	4	8mm Nylon Lock Nuts
4	Mounting Brackets	2	6mm x 30mm Double Bolt Plates
4	Clamping Brackets	8	6mm x 20mm T-Bolts
2	6mm Thick Spacer Plates	16	6mm x 20mm Button Head Combo Bolts
4	50mm x 35mm x 5mm Foam Strips	4	6mm x 20mm Hex Bolts
4	50mm x 30mm x 3mm Foam Strips	12	6mm x 18mm OD x 1.6mm Flat Washers
4	82mm x 33mm x 2mm Foam Strips	8	6mm Nylon Lock Nuts
4	50mm Rubber Trims	8	6mm Flange Nuts
1	Wind Fairing Plate Rubber Trim	1	5mm Hex Wrench
4	Plastic Hex Caps	1	4mm Hex Wrench

CAUTION: Recommended load rate is 300 lbs. Platform only, too much weight will greatly reduce the stability of the vehicle and increase the vehicle's tendency to overturn or damage roof. The manufacturer makes no representation or warranty as to the amount of weight that the vehicle can safely carry. For guidance, we recommend that you consult the vehicle manufacturer. Secure all payloads properly for safe transportation.

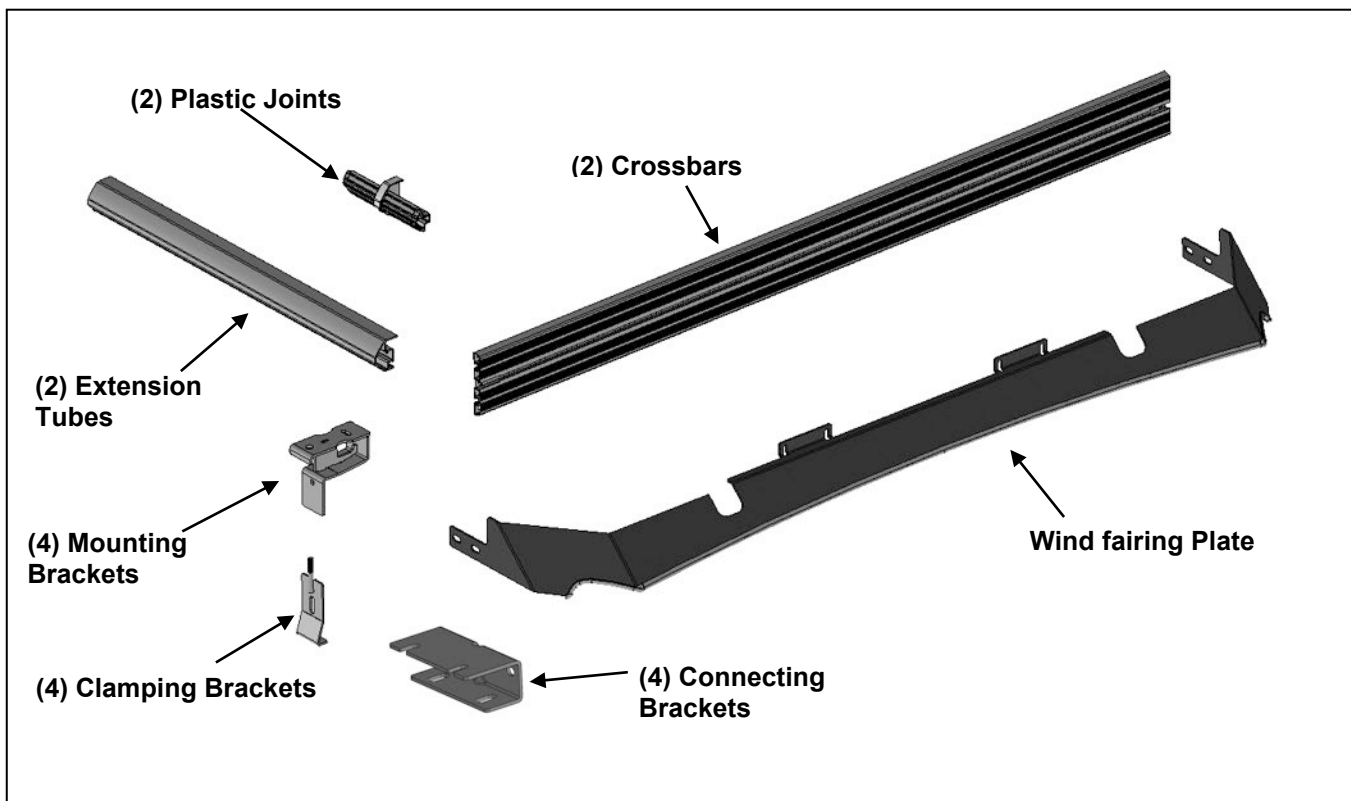

PROCEDURE: REMOVE CONTENTS FROM BOX. VERIFY ALL PARTS ARE PRESENT. READ INSTRUCTIONS CAREFULLY BEFORE STARTING INSTALLATION. ASSISTANCE RECOMMENDED.

1. Temporarily remove the roof rack if previously installed.
2. Separate the (2) halves of the roof rack, keeping (1) plastic joint attached to (1) of the halves. Slide (1) Extension Tube Onto each of the (2) joints in the roof rack. Secure with (4) 6mm Button Head Combo

**PR1 PLATFORM FULL EXTENSION
2018-21 JEEP WRANGLER JL 4 DOOR WITH HARD TOP**

Bolts. Slide (1) Plastic Joint into each of the Extension Tubes. Reattach the other half of the roof rack to the (2) Joints with (8) 6mm Button Head Combo Bolts, **(Figures 1 & 2)**.

3. Move to the front end of the Platform. Temporarily remove the (2) light cube brackets. Slide the Wind Fairing Plate up onto the (4) T-Bolts in the roof rack. Reattach the light cube brackets to the T-Bolts with (4) 6mm Flat Washers and (4) 6mm Flange Nuts, **(Figure 3)**. Slide the Long Rubber Trim onto the front of the Wind Fairing Plate.
4. Attach (2) Connection Brackets to each Extension Tube with (4) 6mm Button Head Combo Bolts, **(Figure 4)**. Slide (2) T-Bolts into each channel in the bottom of each Crossbars. Attach the (2) Crossbars to the (4) Connection Brackets with (8) 6mm Flange Nuts, **(Figure 5)**.
5. Attach (1) Mounting Bracket to each Connection Bracket with (1) 6mm x 20mm Hex Bolt, (2) 6mm Flat Washers and (1) 6mm Nylon Lock Nut, **(Figure 6)**. Do not tighten hardware.
6. With assistance, place the PR1 Platform On top of the vehicle and the bottoms of the Mounting Brackets in the rain gutters. **NOTE:** Place the rear bracket of the Platform approximately 8cm in front of the rear of the rain gutter, **(Figure 7)**.
7. Attach (1) 50mm x 30mm Foam Strip to the inside of the Clamping Brackets, **(Figure 8)**. From below, slide the threads up through the Mounting Brackets and attach the Clamping Brackets to the Mounting Brackets with (4) 8mm Flat Washers and (4) 8mm Nylon Lock Nuts, **(Figure 9)**.
8. Tighten all Clamping Brackets while leveling the Platform. Once leveled, lock the Clamp Brackets in place with (8) 8mm Combo Bolts into the Front and Center Brackets, **(Figure 10)**. Do not tighten hardware.
9. Secure the sides of the Wind Fairing Plate to the front brackets with (4) 8mm Button Head Bolts, (4) 8mm Lock Washers and (4) 8mm Flat Washers, **(Figure 11)**.
10. Level and adjust the PR1 Platform and tighten all hardware.
11. Do periodic inspections to the installation to make sure that all hardware is secure and tight.

To protect your investment, Do not use any type of polish or wax that may contain abrasives that could damage the finish. Mild soap may be used to clean the Roof Rack.

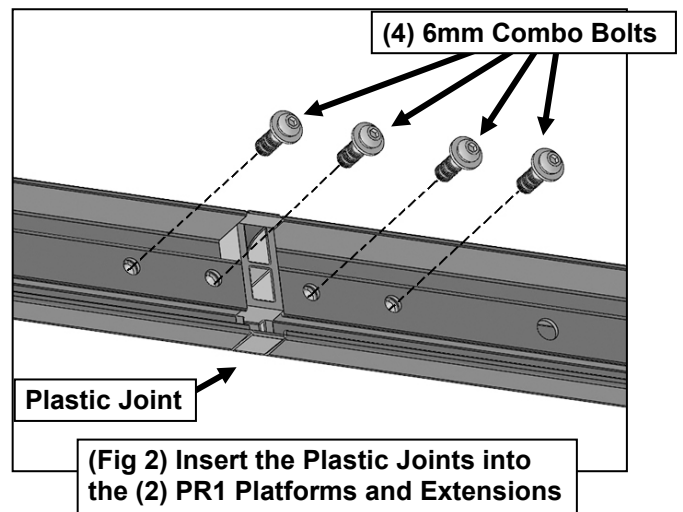
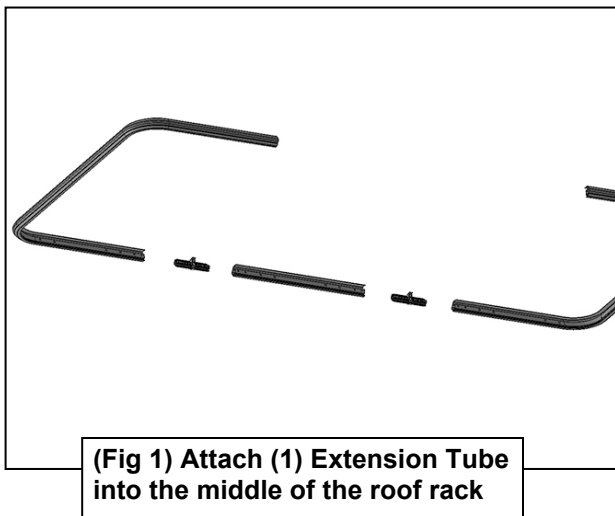

PR1 PLATFORM FULL EXTENSION
2018-21 JEEP WRANGLER JL 4 DOOR WITH HARD TOP

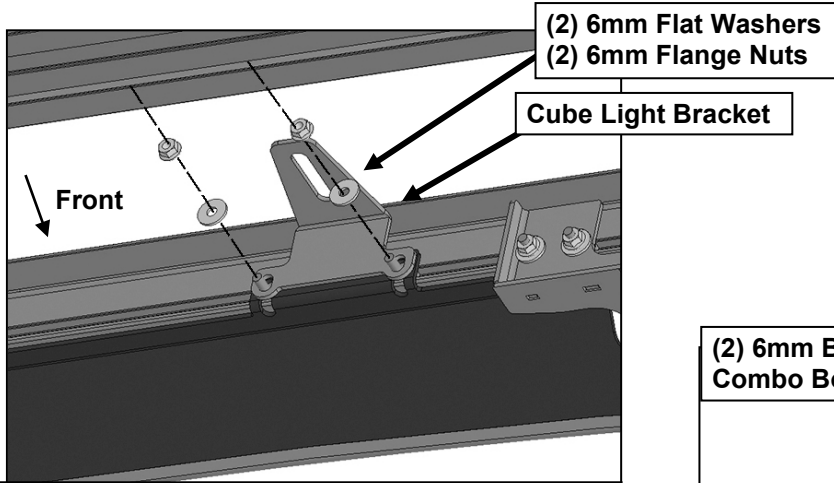

(Fig 3) Remove the hardware attaching the light cube bracket. Use new hardware to attach the Wind Fairing Plate. Slide (1) Long Rubber Trim to the bottom of the Wind Fairing Plate

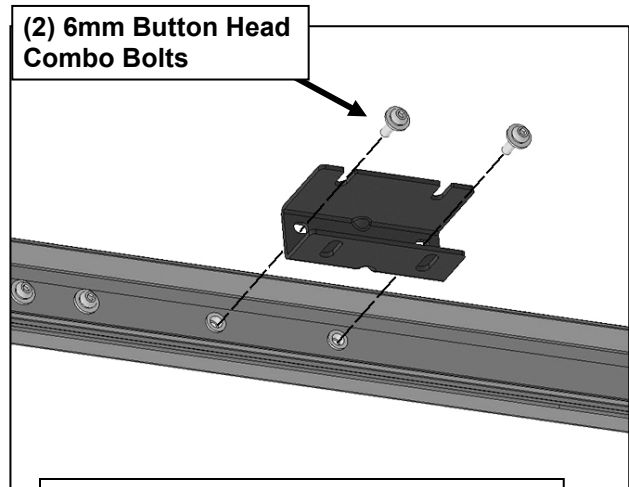

(Fig 4) Attach (1) Connection Bracket to the inside of the Side Extension Tube

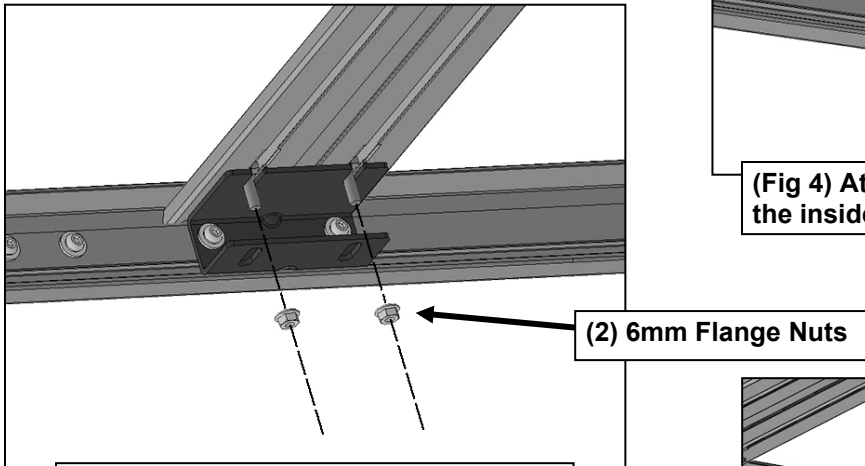

(Fig 5) Insert (4) 6mm T-Bolts into each Crossbar, (2) per channel. Attach the Crossbar to the Connection Brackets

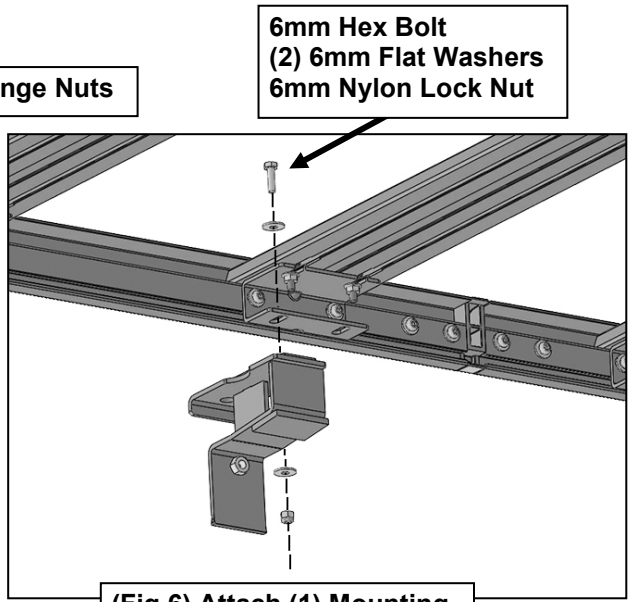

(Fig 6) Attach (1) Mounting Bracket to the crossbar

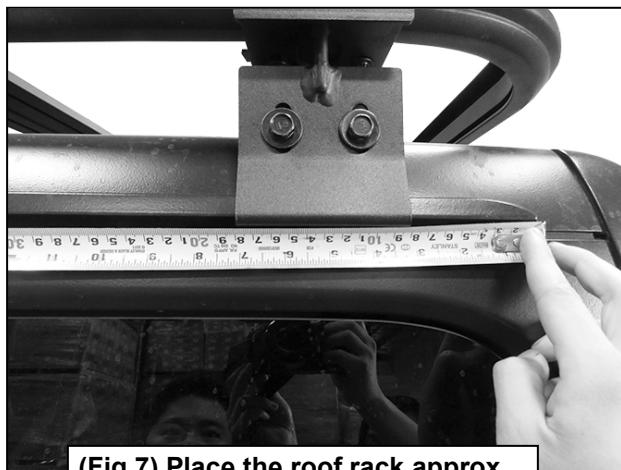

(Fig 7) Place the roof rack approx. 8cm from the rear of the rain gutter

PR1 PLATFORM FULL EXTENSION
2018-21 JEEP WRANGLER JL 4 DOOR WITH HARD TOP

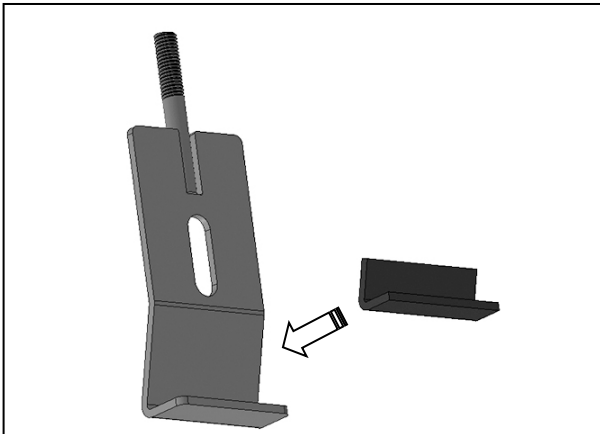

(Fig 8) Attach (1) 50mm x 30mm Foam Strip to the inside of the clamping Brackets

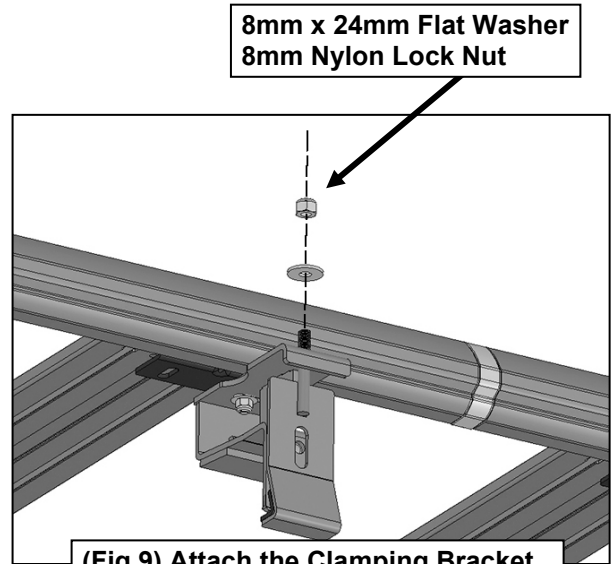

(Fig 9) Attach the Clamping Bracket to the Mounting Bracket and the rain gutter on the side of the vehicle

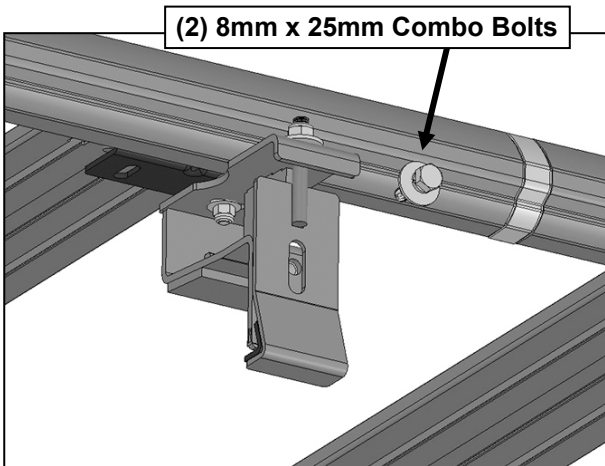

(Fig 10) Secure the Brackets to the rain gutter

- (2) 8mm Button Head Bolts
- (2) 8mm Lock Washers
- (2) 8mm Flat Washers

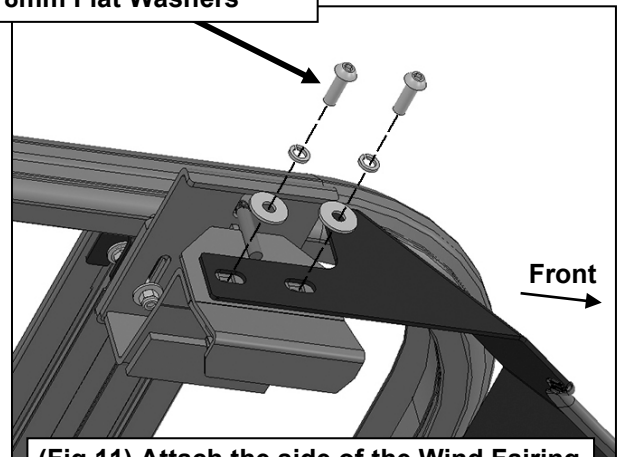

(Fig 11) Attach the side of the Wind Fairing Plate to the front mounting brackets