

PARTS LIST:

1	Driver/Left Fender Assembly	2	8-1.25mm Hex Nuts
1	Passenger/Right Fender Assembly	16	6-1.0mm x 25mm Button Head Bolts
1	6mm Threaded Insert Install Tool	2	6-1.0mm x 20mm Hex Bolts
4	6mm Threaded Inserts	18	6mm x 12mm x 1.6mm Flat Washers
4	8mm Nut Plates	18	6mm Lock Washers
6	8-1.25mm x 25mm Hex Bolts	14	6mm Flange Nuts
8	8mm x 16mm x 1.6mm Flat Washers	1	4mm Hex Wrench
6	8mm Lock Washers	10	Wire Ties

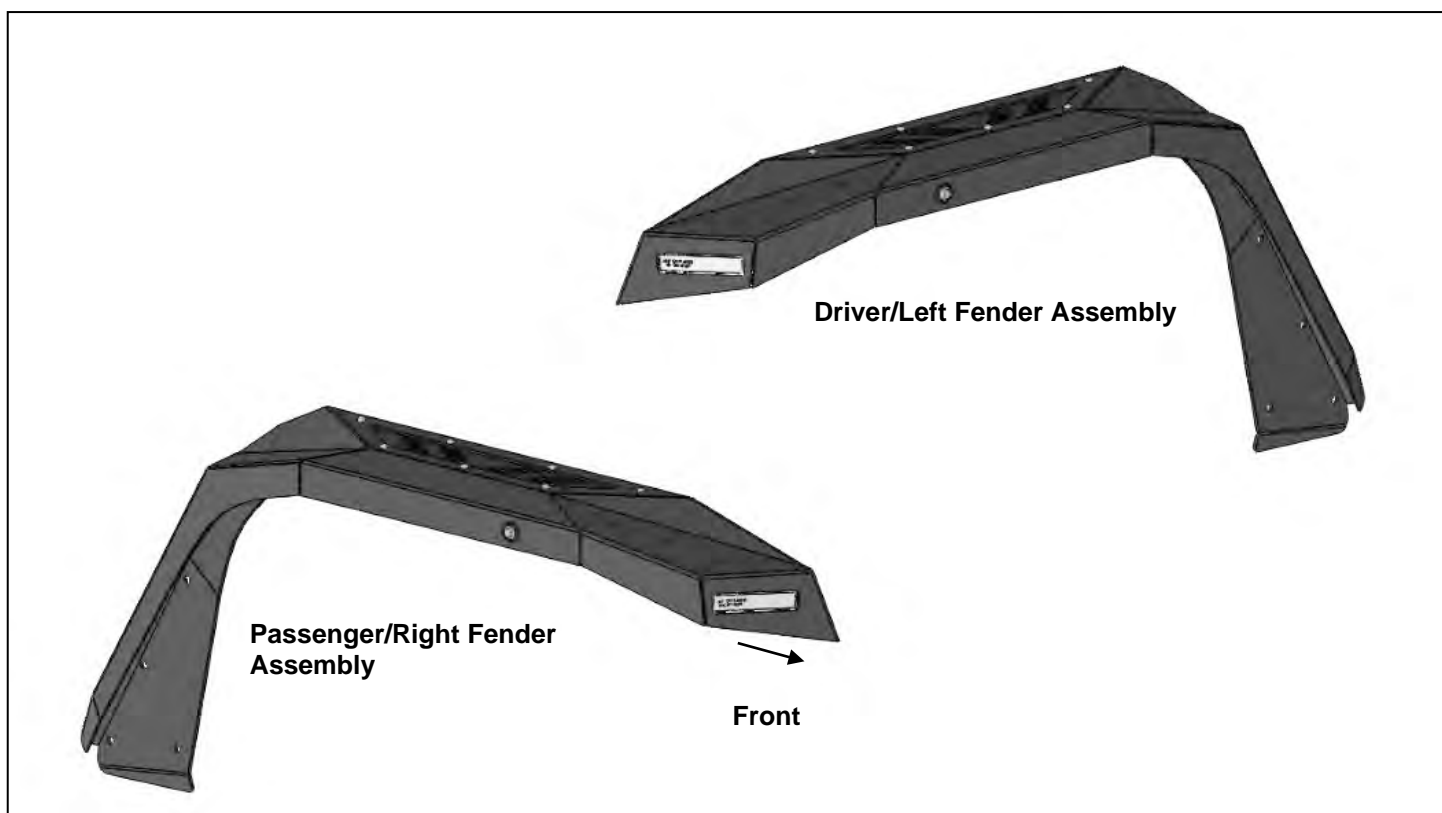

PROCEDURE:

REMOVE CONTENTS FROM BOX. VERIFY ALL PARTS ARE PRESENT. READ INSTRUCTIONS CAREFULLY. CUTTING AND MODIFICATION IS REQUIRED TO REINSTALL THE PLASTIC FENDER LINER. DRILLING IS REQUIRED. ASSISTANCE IS RECOMMENDED.

1. Start installation on the Driver/Left side of the vehicle. Release the plastic clips attaching the liner to the outer edge of the fender and the body, **(Figure 1)**. Locate and remove the bolts attaching the fender liner at the front and top of the liner and remove the fender liner, **(Figure 2)**.
2. Unplug the wiring harness leading from the body to the fender.
3. Next, release the plastic clips attaching the fender to the body. Firmly pull the fender straight outward from the body to pop the clips from the mounting holes, **(Figure 3)**. **OPTION:** Use a pair of needle nose pliers to reach the back of the clip and squeeze the tabs to release. Remove any clips left attached to the body panel and move the fender to a clean surface.
4. Select the Driver/Left Front Fender. Carefully place the Fender on the (2) upper mounting tabs and front tab. Select (1) 8mm Nut Plate, Slide the Nut Plate into one of the channels on the underside of the fender, **(Figure 4)**. Line up the threaded hole in the Nut Plate with the slot in the channel. Attach the Fender with Nut Plate to the support channel with (1) 8mm x 25mm Hex Bolt, (1) 8mm Lock Washer and (1) 8mm Flat Washer, **(Figure 4)**. Do not tighten at this time. Repeat this Step to attach the Fender to the remaining support channel and Nut Plate.

5. Next, attach the Fender to the mounting tab on the front of the body with (1) 8mm x 25mm Hex Bolt, (2) 8mm Flat Washers, (1) 8mm Lock Washer and (1) 8mm Hex Nut, **(Figure 5)**. Do not tighten hardware at this time.
6. Move to the rear of the Fender. Attach the Fender to the lower mounting hole closest to the tire with (1) 6mm Button Head Bolt, (2) 6mm Flat Washers, (1) 6mm Lock Washer and (1) 6mm Hex Nut, **(Figure 6)**. Leave hardware loose at this time.
7. With the Fender loosely attached and lined up with the mounting holes, mark the correct holes that will be drilled for (2) 6mm threaded inserts, **(Figures 7 & 8)**. Temporarily remove the Fender.
8. Use an electric drill and 25/64" drill bit, (not included) to drill out the mounting holes as described in Step 7, **(Figure 8)**. **VERY IMPORTANT:** Only drill through the outer sheet metal to enlarge the holes for a Threaded Insert, **do not drill completely through the body**.
 - a. Select the 6mm Threaded Insert Installation Tool and (1) 6mm Threaded Insert, **(Figure 9-A)**.
 - b. Screw the Insert onto the threaded end of the Insert Tool, **(Figure 9-A)**.
 - c. Firmly hold the Tool and push the Insert into one of the previously drilled holes, **(Figure 9-B)**.
 - d. Insert should fit snug into one of the drilled holes. Lightly tap the Tool and Insert into the hole with a small hammer if necessary.
 - e. Firmly hold the hex nut on the Insert Tool in place with a wrench and turn the hex bolt clockwise to tighten the bolt and expand the Insert in the hole **(Figure 9-C)**.
 - f. Once Insert is fully compressed and expanded, remove the Tool from the Insert, **(Figure 10)**.
WARNING: Do not overtighten Insert or damage to the Insert may result.
 - g. Repeat **Steps 8a—8f** to install the upper Threaded Insert.
9. Repeat **Steps 4—6** to reinstall the Fender.
10. Locate the (6) remaining mounting holes in the Fender and the body panel. Attach the Fender to the body with (6) 6mm Button Head Bolts, (6) 6mm Lock Washers, (6) 6mm Flat Washers and (6) 6mm Flange Nuts. Attach the Fender to the Threaded Inserts with (2) 6mm Button Head Bolt, (2) 6mm Lock Washer and (2) 6mm Flat Washer, **(Figures 11—13)**. Do not fully tighten hardware at this time.
11. Attach the plug on the wiring harness to the factory plug toward back of fender. **IMPORTANT:** Make sure wiring harness is fully protected from heat and that it cannot come in contact with sharp edges along body and fender. Secure harness to vehicle.
12. Determine if vehicle is equipped with standard light package or option LED light package.
Models with standard light package:
 - a. Plug Fender wiring harness into main harness and skip to **Step 13**.
Models with LED option light package:
 - a. Unplug wires leading into and out of the resistor, **(Figures 14A & 14B)**. Resistor is not required for LED light package.
 - b. Seal open plugs on wiring harness with electrical tape.
13. With the fender in place, determine if plastic fender liner will be reinstalled. **NOTE:** Aluminum fender liners, (available separately), are highly recommended.
 - a. Slide plastic fender liner into position.
 - b. Trim the outer edge from the liner to match the Fender. **NOTE:** Actual amount to remove from liner to be determined by installer. Leave as many mounting points on the plastic liner as possible.
 - c. Reinstall modified liner over wiring harness.
14. Adjust the position of the Fender and fully tighten all hardware.
15. Repeat **Steps 1—14** for Passenger/Right side Fender installation.
16. Do periodic inspections to the installation to make sure that all hardware is secure and tight.

To protect your investment, do not use any type of polish or wax that may contain abrasives that could damage the finish. Mild soap may be used to clean the Fenders.

Driver/Left Side Installation Pictured



(Fig 1) Release clips attaching fender liner to outer fender



(Fig 2) Remove hardware attaching fender liner to front, top and back of fender (Passenger/Right side pictured)



(Fig 3) Firmly pull fender straight out from vehicle

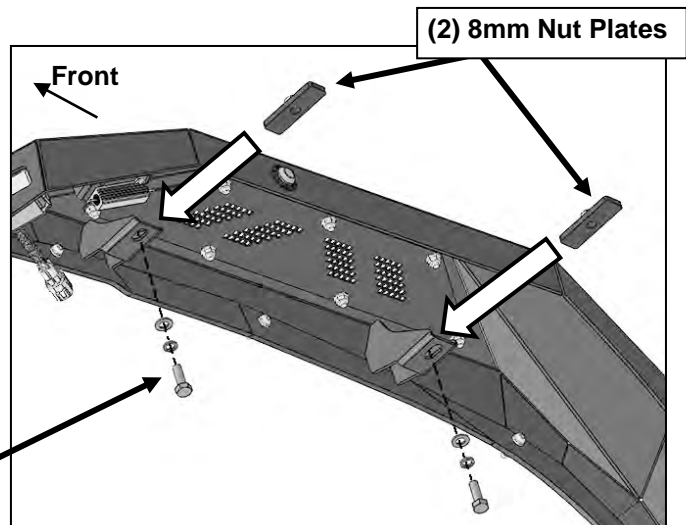

- (2) 8mm x 25mm Hex Bolts
- (2) 8mm Lock Washers
- (2) 8mm Flat Washers

(Fig 4) Hold Fender up in position on fender supports. Slide (2) 8mm Nut Plates into channels under Fender. Attach Fender to fender supports

Driver/Left Side Installation Pictured

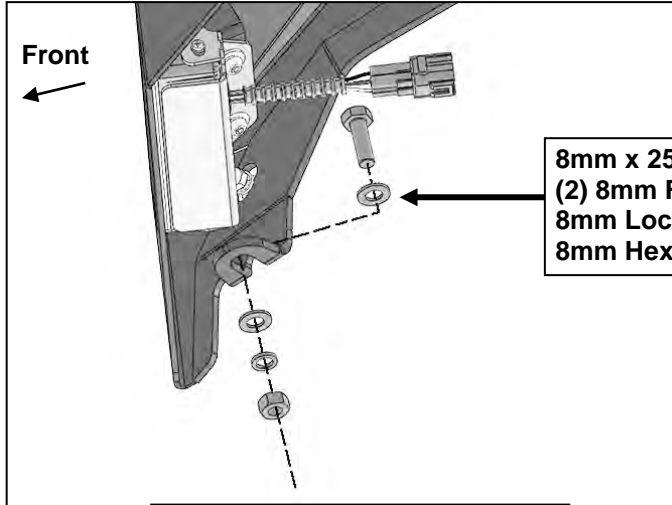

8mm x 25mm Hex Bolt
(2) 8mm Flat Washers
8mm Lock Washer
8mm Hex Nut

6mm x 25mm Button Head Bolt
6mm Lock Washer
6mm Flat Washer
6mm Flange Nut

(Fig 5) Attach front of Fender to mounting tab on body

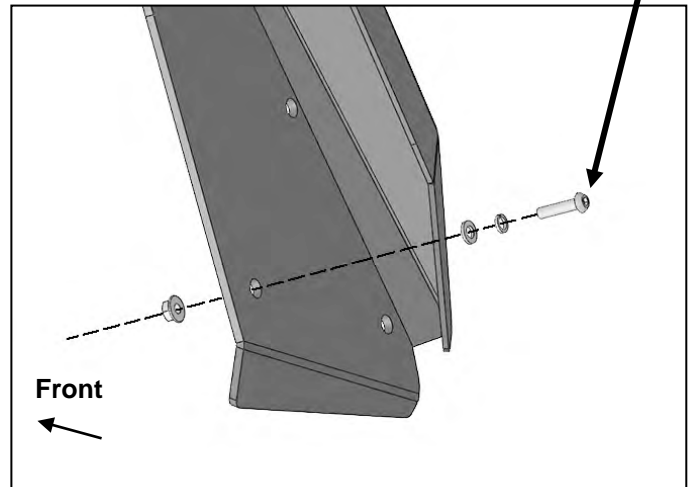

(Fig 6) Attach rear of Fender to hole in side of body

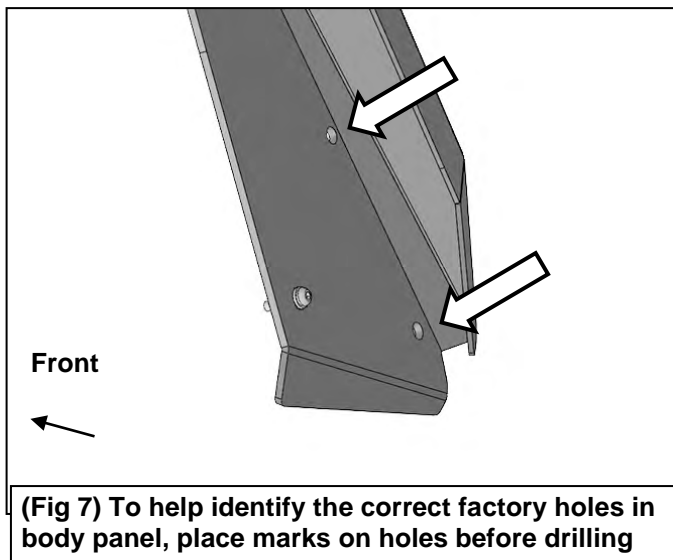

(Fig 7) To help identify the correct factory holes in body panel, place marks on holes before drilling



(Fig 8) Use a 25/64" drill bit to open holes up slightly for Threaded Insert installation (see Fig 7)

Driver/Left Side Installation Pictured

(9-A) Select Insert Tool and (1) Insert. Thread Insert onto end of Insert Tool. Hand tighten only, do not tighten hex bolt

(9-B) Firmly hold assembly and push Insert into drilled hole.

(9-C) Use a wrench (open or box end) to hold nut (arrow) to prevent nut and tool from turning. Hold Tool Assembly up tight in body panel. Turn hex bolt in Tool clockwise to expand insert in body panel. Remove Tool once Insert is fully tightened. Do not overtighten or Insert may be damaged. Repeat steps for all Insert installations

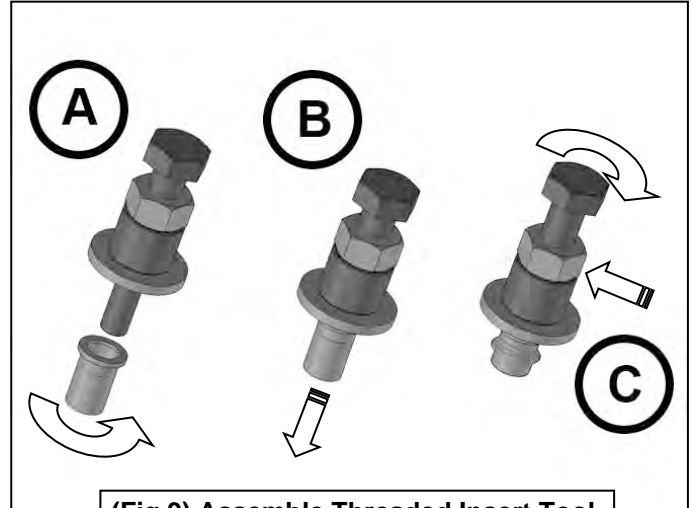

(Fig 9) Assemble Threaded Insert Tool

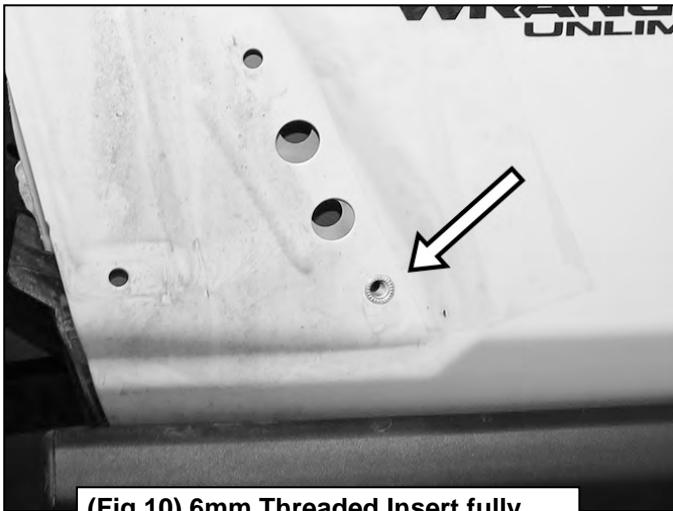

(Fig 10) 6mm Threaded Insert fully installed in lower drill location (arrow)

- (2) 6mm x 25mm Button Head Bolts
- (2) 6mm Lock Washers
- (2) 6mm Flat Washers
- (2) 6mm Flange Nuts

- 6mm x 20mm Hex Bolt
- 6mm Lock Washer
- 6mm Flat Washer
- 6mm Flange Nut

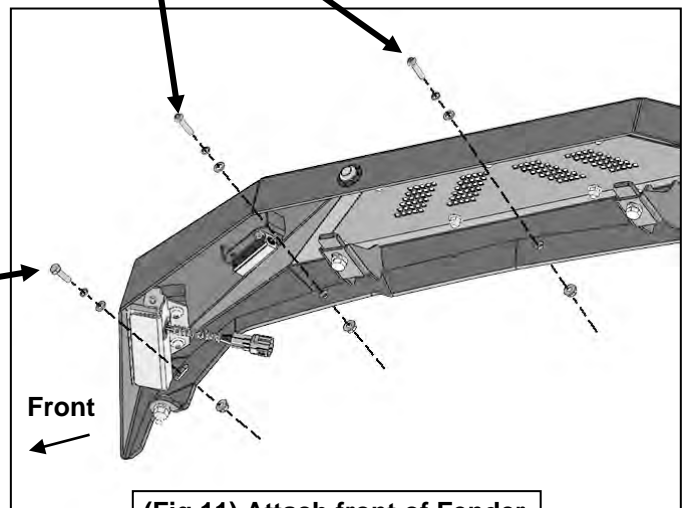

(Fig 11) Attach front of Fender to front (3) mounting locations

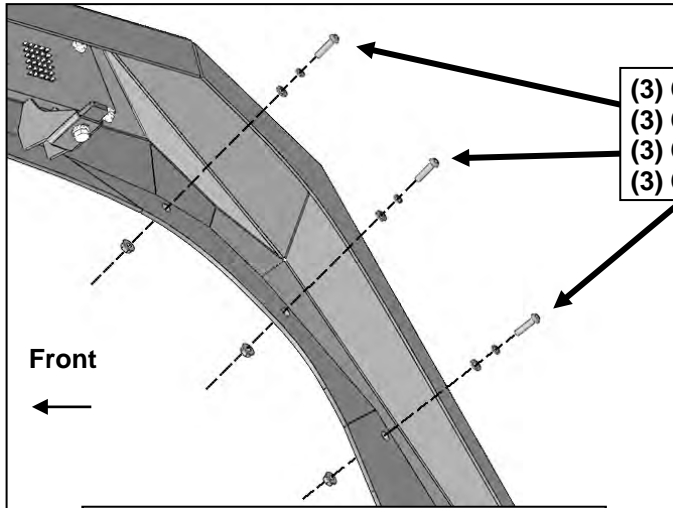

- (3) 6mm Button Head Bolts
- (3) 6mm Lock Washers
- (3) 6mm Flat Washers
- (3) 6mm Flange Nuts

- (2) 6mm Button Head Bolts
- (2) 6mm Lock Washers
- (2) 6mm Flat Washers
- Into Threaded Inserts

(Fig 12) Attach Fender to side of body

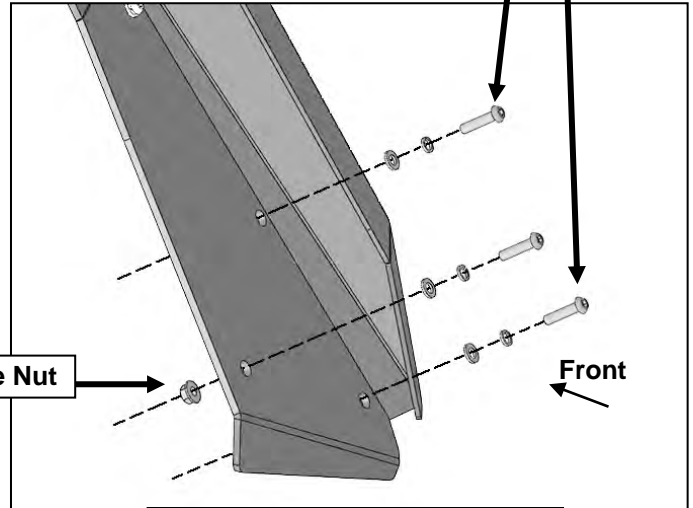

6mm Flange Nut

(Fig 13) Attach front of Fender to rear (3) mounting locations

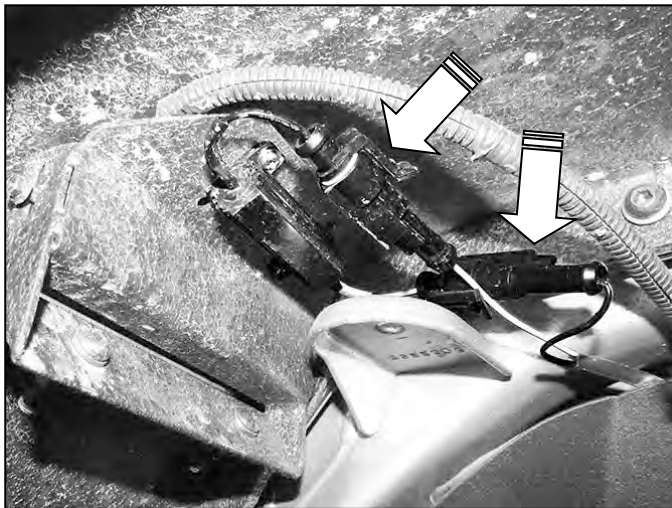

(Fig 14A) Models with factory LED lighting package, unplug both connectors (arrows) leading to and from the resistor. Seal open connectors with waterproof tape or sealant (not included)

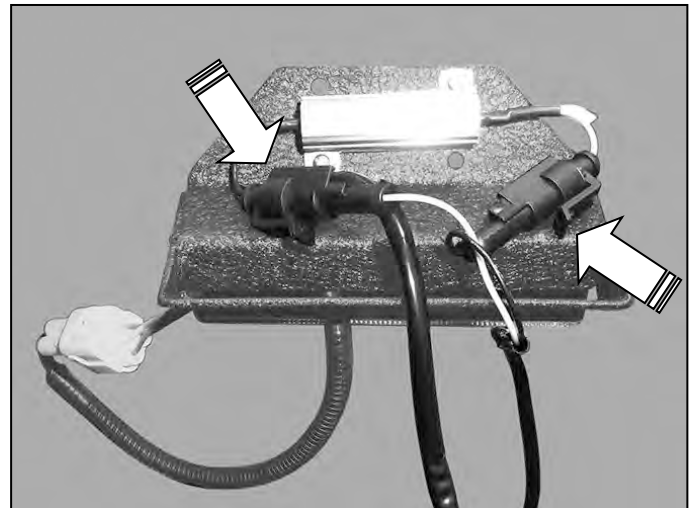

(Fig 14B) Models with factory LED lighting package, unplug both connectors (arrows) leading to and from the resistor. Seal open connectors on harness with waterproof tape or sealant (not included). NOTE: Light assembly removed for instruction purposes only-do not remove light (Fig 14A).