



## 2 Piece Soft Door Installation Instructions

For: Wrangler/TJ (1997-on)

Part Number: 51789

*Note: Use of this product will eliminate the factory side mirrors and requires the removal of the entry light bulbs.*

### WARNING

This product is designed primarily to enhance the appearance of the vehicle and to shield the occupants from ordinary weather conditions. Do not rely in any way on the components of this product to contain occupants within the vehicle, or to protect against injury or death in the event of an accident. This product will not protect the occupants from falling objects. Never operate vehicle in excess of manufacturer's specifications.

#### WEAR SEAT BELTS AT ALL TIMES

Read and follow, precisely, all installation instructions provided when installing this product. Failure to do so may result in poor fit and could place occupants of the vehicle in a potentially dangerous situation.

### Installation Tips

Before you begin installing this door assembly, read all instructions thoroughly. Below are a few tips to make this installation easier.

#### **For a smooth fit:**

It is normal for fabric to contract and wrinkle when stored in the shipping carton. Within a few days after the installation, the fabric will relax and the wrinkles will disappear.

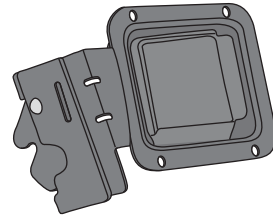

## Parts List and Hardware Identification

Door, Upper - Right	Qty - 1
Door, Upper - Left	Qty - 1
Door, Lower - Right	Qty - 1
Door, Lower - Left	Qty - 1
Spacer Kit	Qty - 1



Latches-Rotary Paddle Handle,  
Rt, Qty 1, Part Number 454.42  
Lt, Qty-1, Part Number 454.43

Tools Needed
Phillips Head Screwdriver
1/8" Allen Wrench
7/16" Wrench
Phillips Head Screwdriver
13mm Wrench

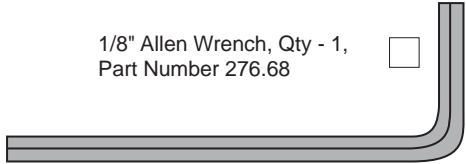
	<input type="checkbox"/>	#10-24 Truss Head Machine Screw - Black, Qty - 8, Part Number 195.92
	<input type="checkbox"/>	#10-24 Locknut, Qty - 8, Part Number 195.93
	<input type="checkbox"/>	1/8" Allen Wrench, Qty - 1, Part Number 276.68

**STOP** If your vehicle does not have the latch pin assembly illustrated here, you have an incorrect part for your vehicle. Please call the 1-800-845-3567 before attempting installation.

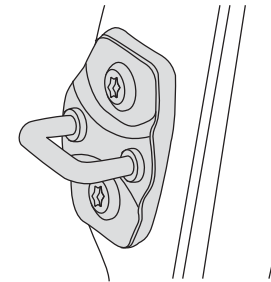

Special Note: The Rotary Latch Paddle Handle will only latch on the automobile manufacturer's original equipment steel latch pin located on the vehicle. Do Not adjust or remove this part.

**WARNING** The doors in this product are designed only for protection against the elements. Do not rely on the doors to contain occupants within the vehicle or to protect against injury during an accident. Door handles are only designed to aid in door closure. Door and handle will not support a person's weight.

## Step One

Remove the factory steel door by removing the hinge pin nuts and lifting the door up and out of the body hinge. Remove any entry lights that are on when the doors are removed.

## WARNING

It is important that the Paddle Handle **must align correctly** with the automobile manufacturer's original equipment steel latch pin located on the vehicle. **Failure to properly install the paddle handle may result in the door accidentally opening. IMPROPER CLOSURE COULD RESULT IN SERIOUS INJURY OR DEATH TO THE OCCUPANTS. WEAR SEAT BELTS AT ALL TIMES. DRIVE CAREFULLY.**

**CAUTION: DO NOT** attempt to adjust the Original Equipment Latch Pin (illustrated on Page 2). Doing so could result in damage to the pin.

## Step Two

Remove the plastic caps from the upper door pins and from the Lower Door Hinge Pins. Locate the pre-cut "X" in the lower door panel where the Paddle Handle will fit into the mounting plate on the door frame. Fold the pre-cut fabric back and insert the Paddle Handle into the mounting plate so that the latch mechanism is inside of the vehicle and the Rotary Latch Mechanism is toward the rear of the door. Align the four holes in the Paddle Handle Assembly with the four holes in the mounting plate. Use a pointed tool to punch four holes in the fabric to match the holes in the Paddle Handle and the mounting plate. Insert four #10-24 Truss Head Machine Screws from the outside and secure them with #10-24 Locknuts. Do not tighten the screws until all four are in place. **Important: You should check alignment of the Paddle Handle to the steel latch pin before tightening the screws. If out of alignment, align and retighten the screws securely.** Trim the excess fabric around the Paddle Handle. Repeat for both lower doors.

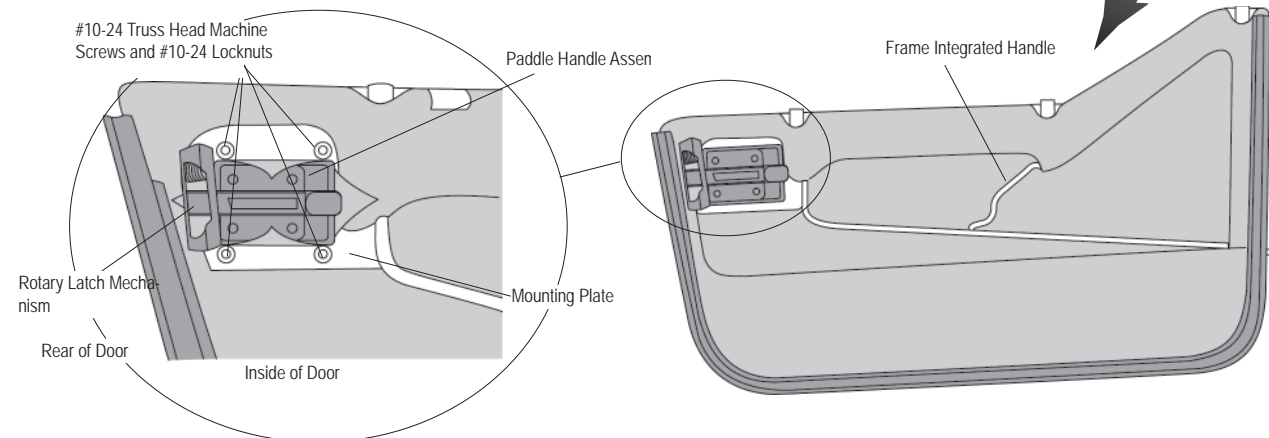
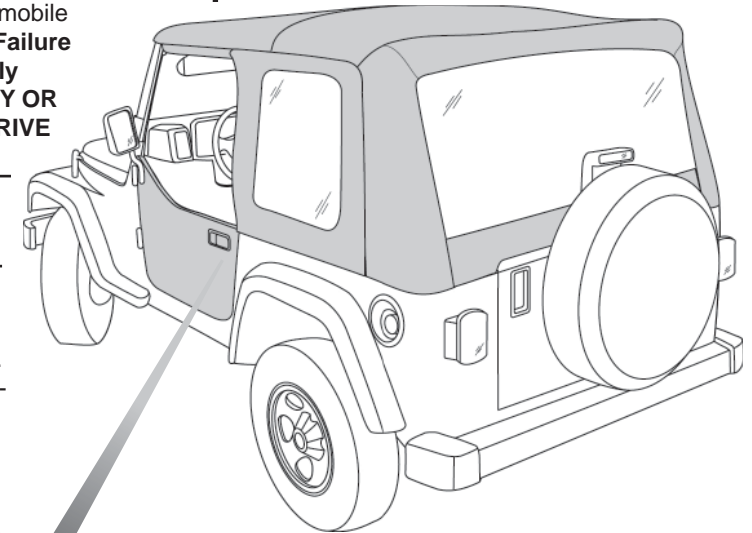

### Step Three

Hold the door straight out from the vehicle with the hinge pins over the body hinges. Lower the pins into the hinges. Make sure that the pins are fully inserted into the body hinges. Close the door and check all sides to make sure that it fits properly against the body.

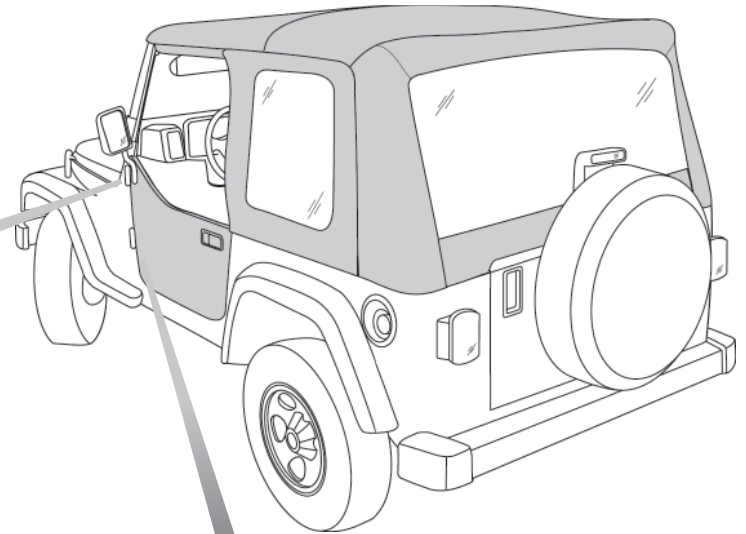
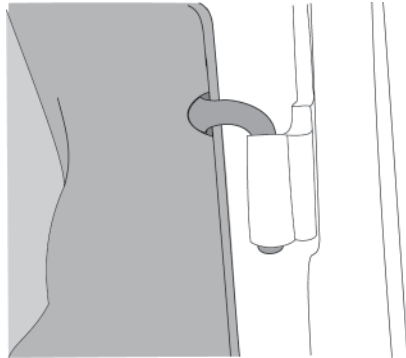

### Step Four

Locate the Lower Hinge Pin Adjustment Plate on the Lower Door frame. If the Lower Door needs to be adjusted for a better fit against the body, use a 7/16" Wrench to loosen the two nuts in the adjustment plate. Slide the Hinge Pin backward or forward as necessary for the best fit. Tighten the nuts.

Readjust the Paddle Handle if necessary.

**Note:** If the lower door pivot does not provide enough adjustability for correct latch adjustment (the door does not latch properly), follow the instructions in the enclosed spacer kit.

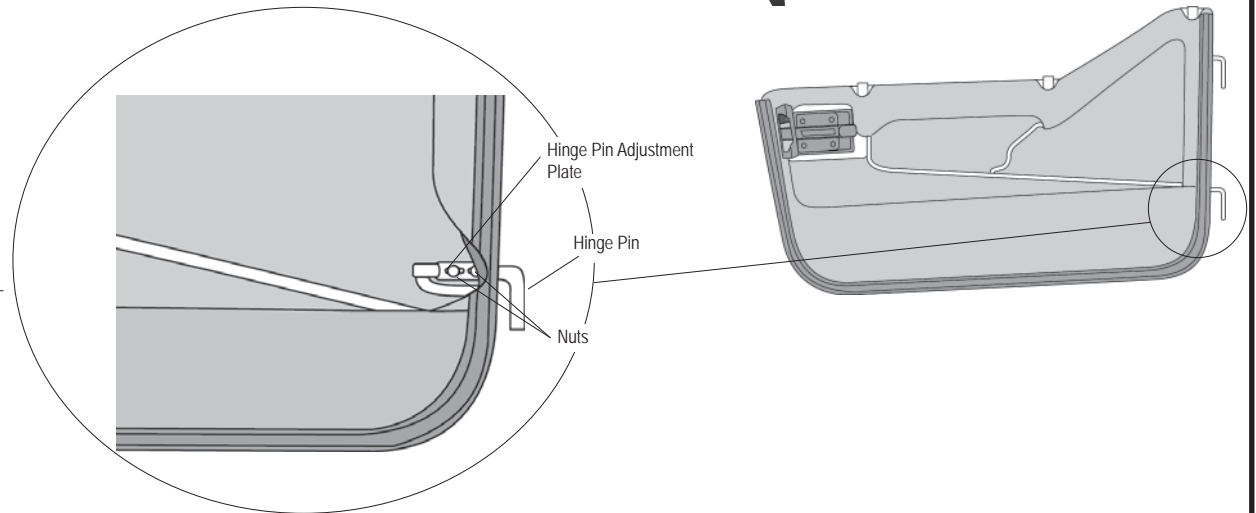

## Step Five

Install the upper door into the lower door. Starting with the front pin, slip the pins into the sockets in the lower door. Make sure that the pins are well seated in the sockets. Close the door to check that it fits properly against the body. If necessary, use a 1/8" Allen Wrench to loosen the Collars on the front and rear upper door pins. The Collars will slide up or down as needed to provide the best fit of the Upper Door against the windshield. Attach the loop strip on the bottom of the upper door to the hook strip on the top of the lower door. If necessary for proper door fit, bend the door slightly.

**Note:** Lubricating the upper door pins with a light weight oil will make it easier to install and remove the upper door.

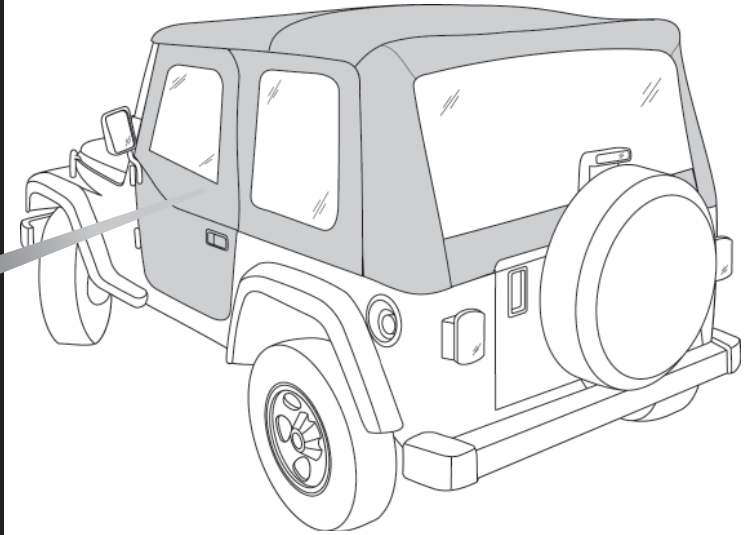
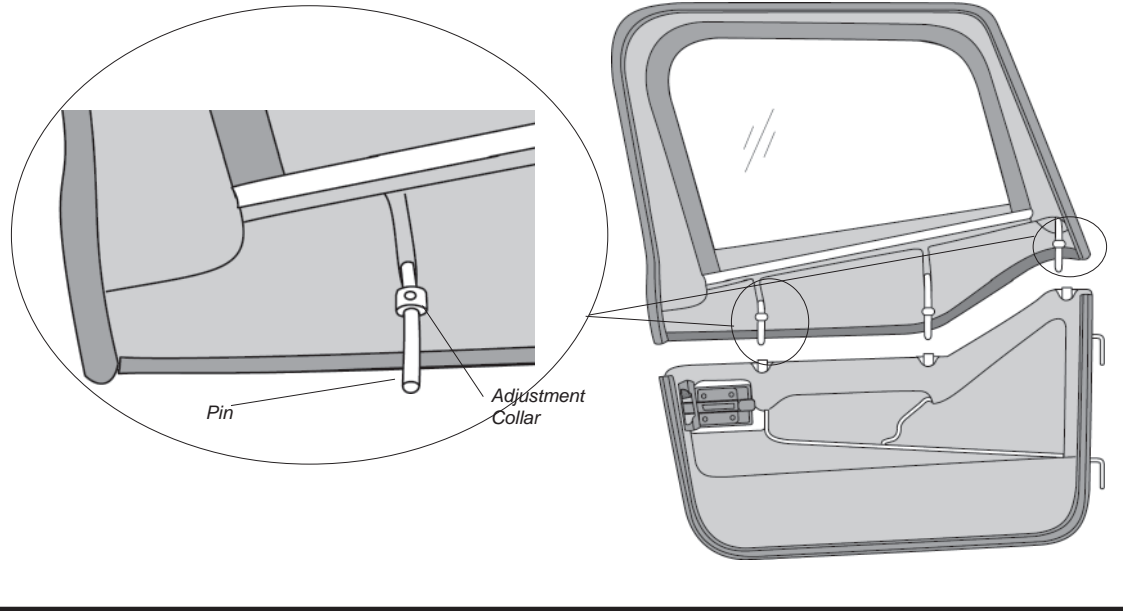

## Care and Maintenance of your Bestop Top

Your top is made of the finest materials available. To keep it looking new and for the maximum possible wear, it will need periodic cleaning and maintenance.

**Washing:** The top fabric should be washed often using soap, warm water and a soft bristle brush. Rinse with clear water to remove all traces of soap.

**Windows:** Keep windows clean to avoid scratching. DO NOT use a brush on the windows! Wash with a watersoaked cloth or sponge and a mild dishwashing detergent. NEVER WIPE THE WINDOWS WHEN THEY ARE DRY. Be careful when cleaning snow or frost from the vinyl windows since they are easily scratched and may crack at low temperatures. DO NOT roll the sides or rear window in cold weather. The windows become stiff and will crack.

**Zippers:** Keeping the zipper cleaned and lubricated with a silicone lubricant will help prevent damage and keep the zippers in a smooth working condition. If a zipper opens behind the slider, the slider may have been spread apart. This problem can usually be repaired by using an ordinary pair of pliers to bring the sides back into parallel. Return slider to the end of the zipper in the normal Open position. Squeeze lightly at first and test the zipper. If the zipper continues to remain open squeeze more firmly with the pliers and try the zipper again. Repeat this procedure until the zipper operates correctly.

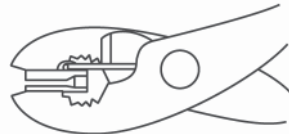
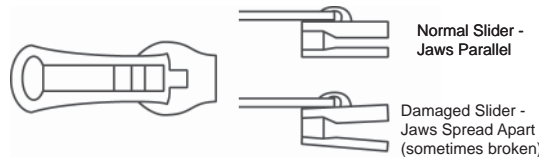

**Water:** Seeping through at the seams may be stopped by applying 3-M Scotchgard® on the inside of the seams. Rips in the fabric may be repaired with Bondex® iron on patches. Iron the patches to the Inside of the top, carefully following the Bondex® instructions.

**Snaps:** Keep snaps cleaned and lubricated with silicone to help prevent snaps from sticking to the studs. If a snap does become stuck to a stud, use a screwdriver and GENTLY pry apart to prevent permanent damage to the snap or the top fabric.

## LIMITED WARRANTY

We warrant our product to be free from defects in material and workmanship, for the terms specified below, provided there has been normal use and proper maintenance. This warranty applies to the original purchaser only. All remedies under this warranty are limited to the repair or replacement of any item or items found by the factory to be defective within the time period specified.

If you have a warranty claim, first you must call our factory at the number below for instructions. You must retain proof of purchase and submit a copy with any items returned for warranty work. Upon completion of warranty work, if any, we will return the repaired or replaced item or items to you freight prepaid. Damage to our products caused by accidents, fire, vandalism, negligence, misinstallation, misuse, Acts of God, or by defective parts not manufactured by us, is not covered under this warranty.

THE WARRANTY TIME PERIOD IS AS FOLLOWS: ALL "SOFT GOODS" MANUFACTURED BY OUR COMPANY (USING PRIMARILY VINYL, PLASTICS, AND/OR FOAM): ONE YEAR FROM DATE OF PURCHASE.

ANY IMPLIED WARRANTIES OF MERCHANTABILITY AND/OR FITNESS FOR A PARTICULAR PURPOSE CREATED HEREBY ARE LIMITED IN DURATION TO THE SAME DURATION AND SCOPE AS THE EXPRESS WRITTEN WARRANTY. OUR COMPANY SHALL NOT BE LIABLE FOR ANY INCIDENTAL OR CONSEQUENTIAL DAMAGE.

Some states do not allow limitations on how long an implied warranty lasts, or the exclusion or limitation of incidental or consequential damages, so the above limitations or exclusions may not apply to you.

This warranty gives you specific legal rights, and you may also have other rights which vary from state to state.

For further information or request for warranty work, please contact:

Bestop Inc.  
Customer Service  
(800) 845-3567  
(303) 465-1755